

# **PCBN Insert For Machining Powder Metallurgy**

**北京沃尔德金刚石工具股份有限公司**  
BEIJING WORLDIA DIAMOND TOOLS CO.,LTD.

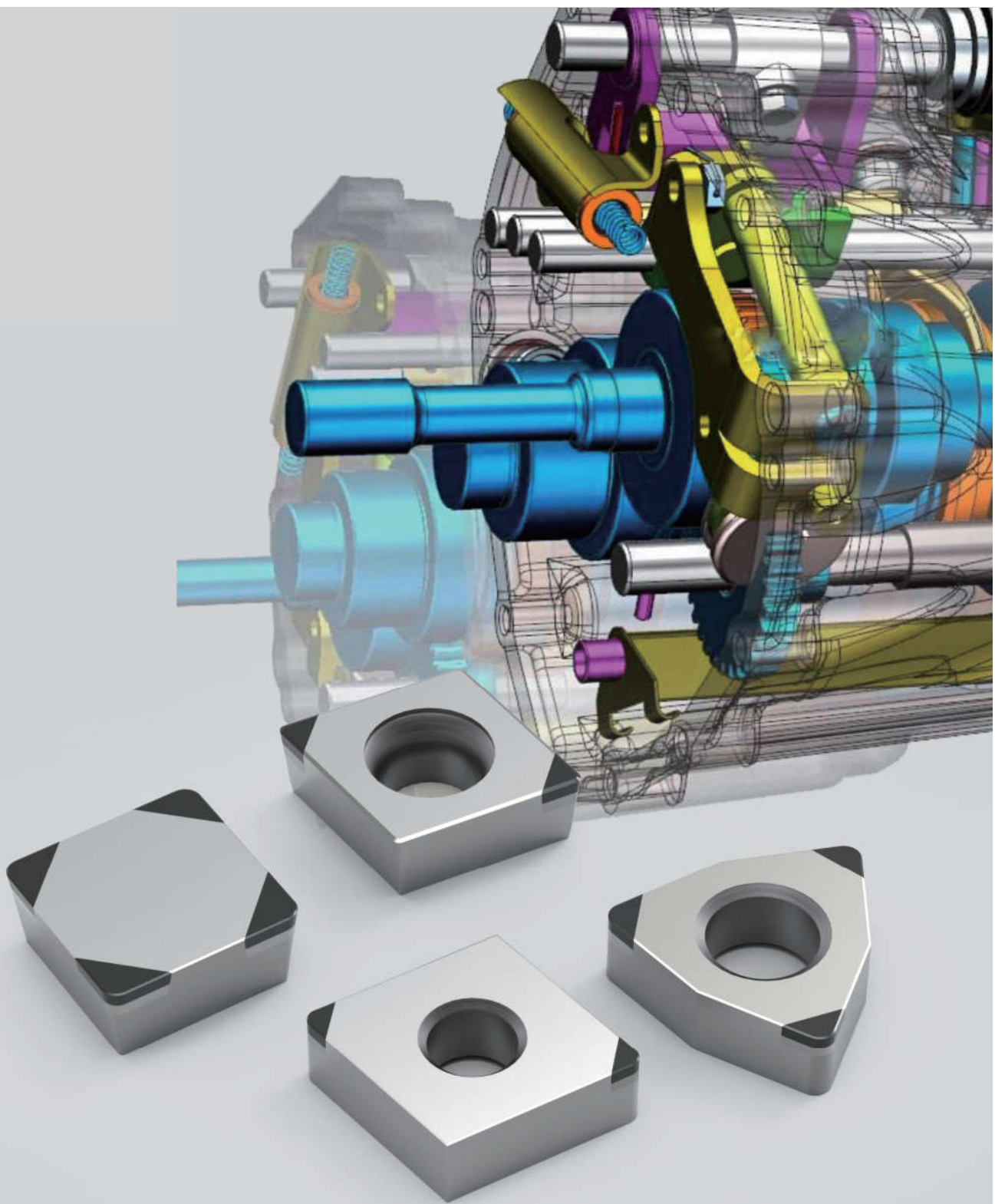

Worldia developed PCBN inserts for the auto manufacture industry, mainly in the field of construction machinery and transportation industry. Such as for processing powder metallurgy workpieces: transmission gearbox, valve body and etc.

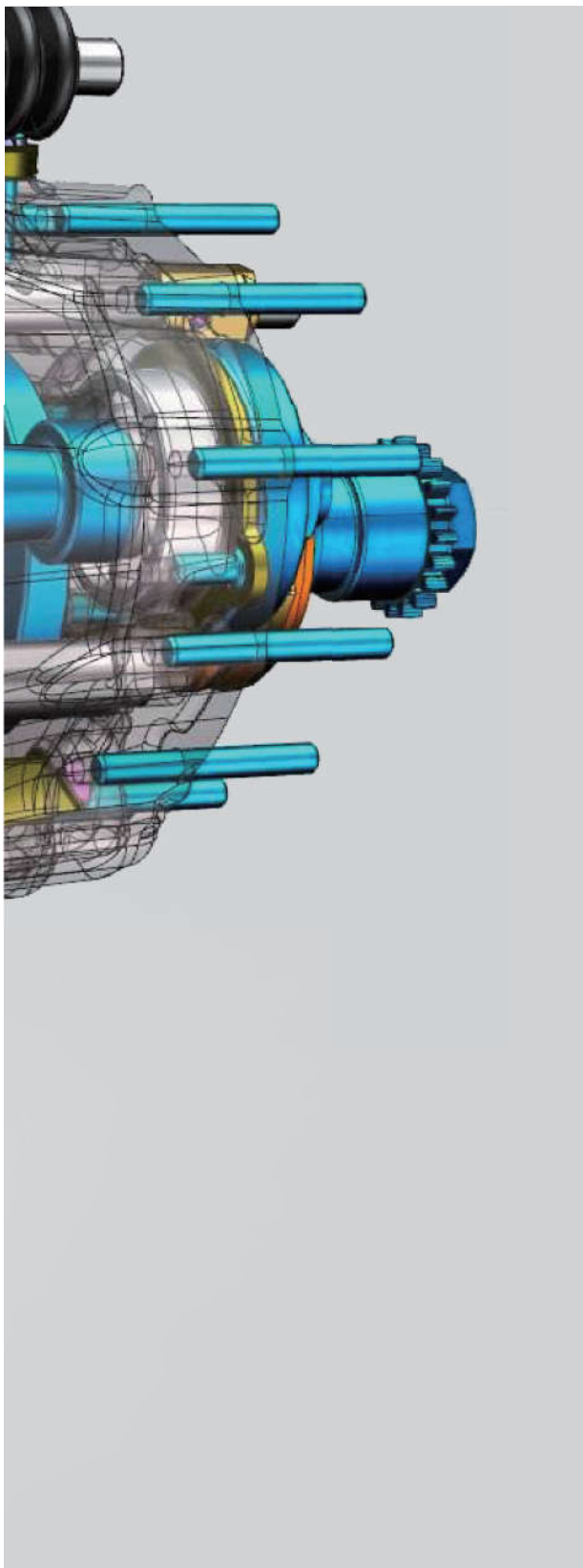

# INDEX

PCBN Material Introduction .....	03
PCBN Insert Identification Code.....	05
Processing Cases .....	06
Rule of PCBN Insert Code .....	09
Specifications of Mini PCBN Insert .....	11
Specifications of Standard PCBN Insert .....	28
Specifications of Wiper PCBN Insert .....	45
Technical Data .....	48

■ Material Group (ISO513 Standard)



## PCBN Material Introduction

Cubic boron nitride is the second hardest material in the world invented successfully in 1957; The microhardness of CBN's single crystal is HV8000-9000 while the hardness of PCBN is HV2500-5000, so it is considerably better abrasive resistance than tungsten carbide and ceramics.

With a higher ability of oxidation resistance within 1000℃, CBN will do not have any chemical reaction together with ferrous material in 1200-1300℃. So it is unique for CBN material dry cutting ferrous materials. The principal application areas for CBN cutting tools are hardened steels, cast irons and sintered irons as well as powder metallurgy components.

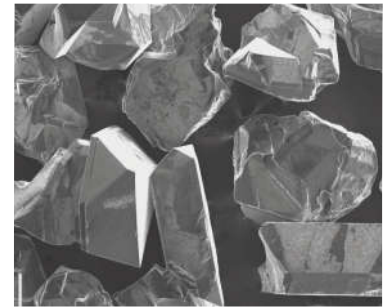

■ Material Code Key

<b>PN</b>	<b>S01</b>	<b>15</b>
PCBN	Application	Material Code

Material	Application	Material Code	Characteristics
PN	S01	15	Speed ↑
	S20		Abrasive Resistance ↑
			↓ Interruption      ↓ Tenacity

■ Power metallurgy

Workpiece Material	WORLDIA PCBN Grades	Content	PCBN Grade	Hardness	Characteristics
S	PNS0115	85°90	5	3700°3900	Extreme abrasion resistance
	PNS0119	90°95	2	3700°3900	Excellent impact resistance and abrasion resistance
	PNS0121	60°70	2	2700°2900	Excellent toughness
	PNS2019	85°90	1	3700°3900	Combination of abrasion resistance and impact resistance

## ■ Cutting Data Recommendations

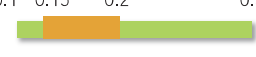
PCBN Grade	Cutting Condition Recommendations		
	Cutting Speed (m/min)	Feed Rate (mm/r)	Cutting Depth (mm)
PNS0115			Continuous machining of powder metallurgy
PNS0119			Continuous and <b>lightly</b> interrupted machining of powder metallurgy
PNS0121			Continuous and interrupted machining of hard-to-work powder metallurgy
PNS2019			Strongly interrupted machining of powder metallurgy

## ■ PCBN Inserts

Sharp Cutting Edge: E0000005

Standard Cutting Edge: S0101505

Strong Cutting Edge: S0102510

## ■ Cutting Edge of Recommendation

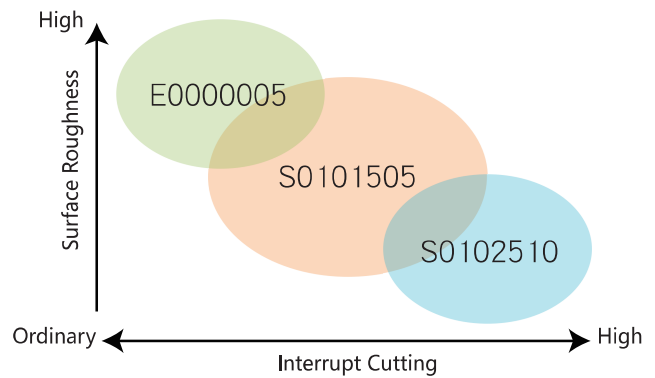

# PCBN Insert Identification Code

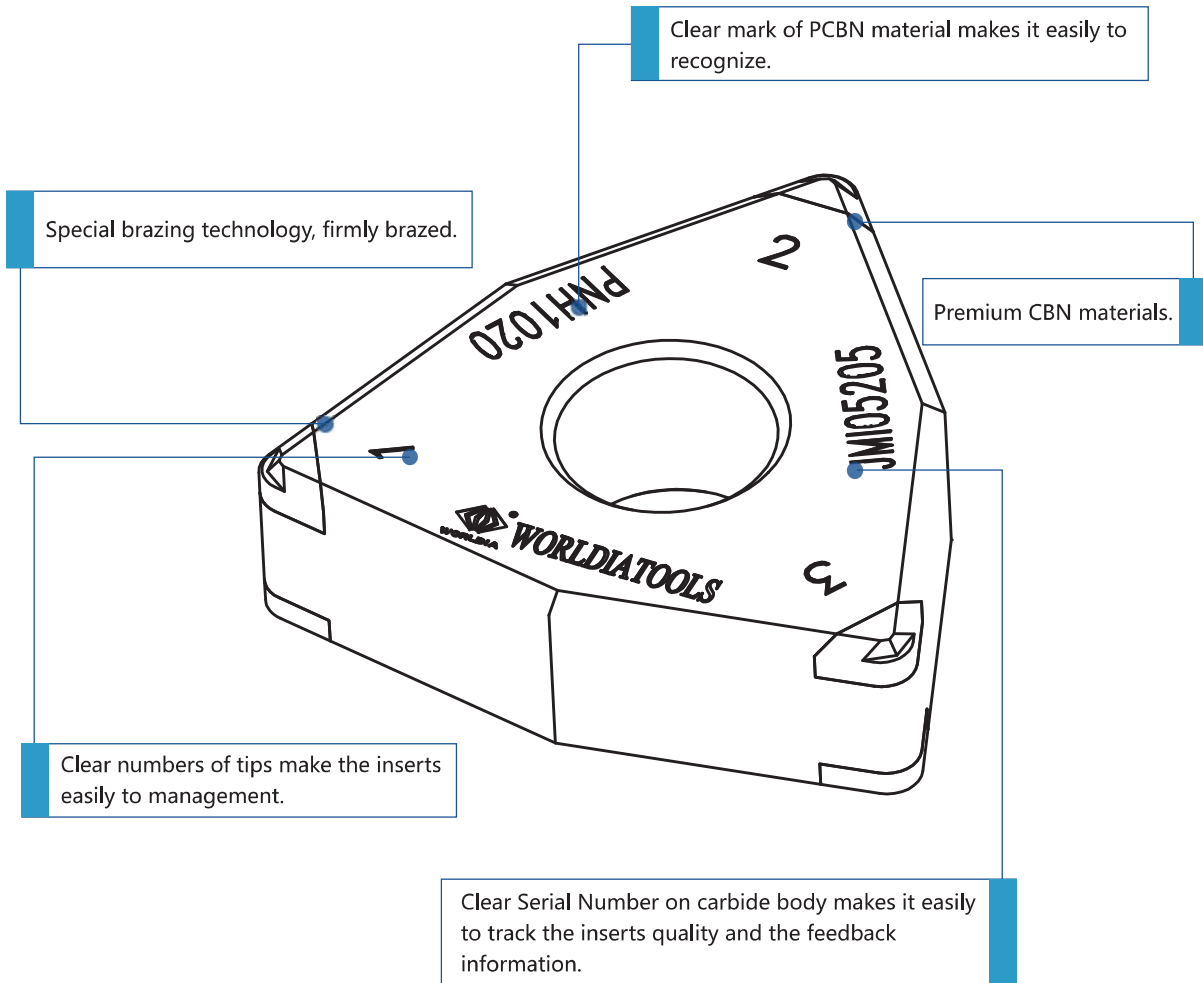

# Processing cases

## Transmission Gear Hub

Finishing end face and annular groove

PCBN Grade	Competition	WORLDIA PNS2017
Insert type	DCGW11T304-2N	DCGW11T304-2N
Speed(m/min)	500	500
Feed(mm/r)	0.1	0.1
Cutting depth(mm)	0.2	0.2
Qty/1tip	106	145
Comparison of tool life	100%	137%

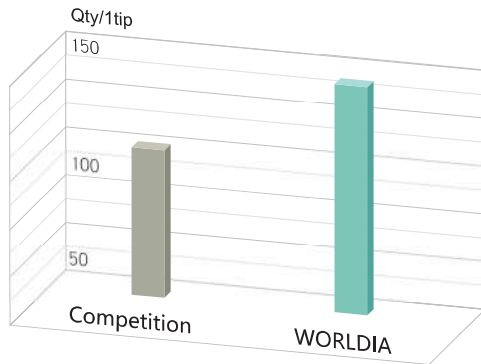

## Cylinder Seat

Finishing inner hole

PCBN Grade	Competition	WORLDIA PNS0123
Insert type	CPGW060204-2N	CCGW060204-2N
Speed(m/min)	150	150
Feed(mm/r)	0.05	0.05
Cutting depth(mm)	0.2	0.2
Qty/1tip	100	120
Comparison of tool life	100%	120%

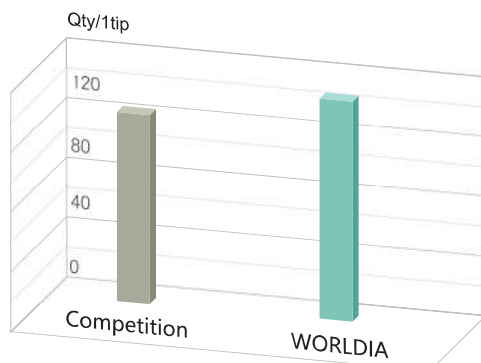

# Processing cases

## Transmission Gearbox

Finishing end face

PCBN Grade	Competition	WORLDIA PNS2017
Insert type	DCGW11T304-2N	DCGW11T304-2N
Speed(m/min)	500	500
Feed(mm/r)	0.1	0.1
Cutting depth(mm)	0.2	0.2
Qty/1tip	106	145
Comparison of tool life	100%	137%

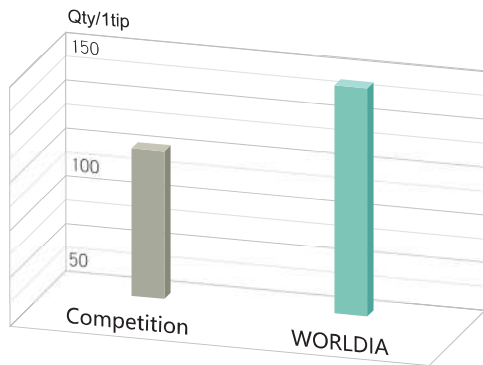

## Transmission Gear Hub

Finishing end face

PCBN Grade	Competition Carbide	WORLDIA PNS0122
Insert type	CNGA120408-4N	CNGA120408-4N
Speed(m/min)	57	200
Feed(mm/r)	0.07	0.1
Cutting depth(mm)	0.25	0.25
Qty/1tip	60	700
Comparison of tool life	100%	1167%

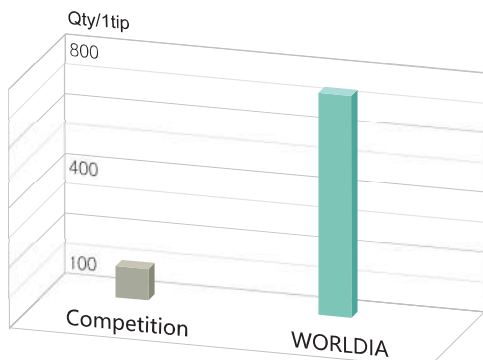



# Processing cases

## ■ Auto Camshaft

Finishing end face, back chipping

PCBN Grade	Competition	WORLDIA PNS0121
Insert type	VBGW 160408-2N	VBGW 160408-2N
Speed(m/min)	210	210
Feed(mm/r)	0.15	0.15
Cutting depth(mm)	0.3	0.3
Qty/1tip	610	1007
Comparison of tool life	100%	165%

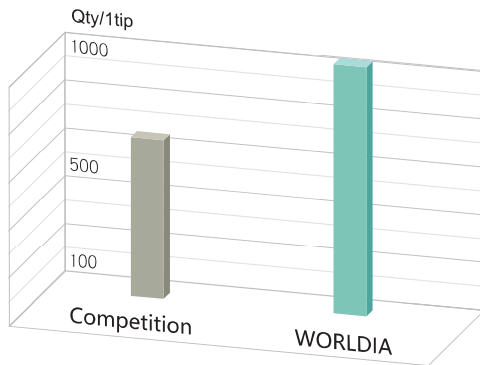

ISO	<b>C</b>	<b>C</b>	<b>M</b>	<b>W</b>	<b>09</b>	<b>T3</b>	<b>04</b>	<b>1</b>	<b>N</b>	<b>S</b>	<b>010</b>	<b>20</b>	<b>05</b>	<b>CB</b>	<b>ST</b>	<b>30</b>	<b>S</b>	<b>PNH1020</b>
	1	2	3	4	5	6	7	8	9	10	11	12	13	14	15	16	17	18

ANSI	<b>C</b>	<b>C</b>	<b>M</b>	<b>W</b>	<b>3(2.5)</b>	<b>1</b>	<b>1</b>	<b>N</b>	<b>S</b>	<b>010</b>	<b>20</b>	<b>05</b>	<b>CB</b>	<b>ST</b>	<b>30</b>	<b>S</b>	<b>PNH1020</b>	
	1	2	3	4	5	6	7	8	9	10	11	12	13	14	15	16	17	18

## Rule of PCBN Insert Code

1 Shape					
	H	120°		C	80°
	O	135°		D	55°
	P	108°		E	75°
	R			M	86°
	S	90°		V	35°
	T	60°		W	80°
				L	90°
				A	85°
				B	82°
			K	55°	

3 Tolerance-ISO	Tolerance-ANSI							
	Code	inch(mm)			Code	inch		
	级	m	s	IC		m	ic	s
	<b>C</b>	±0.013	±0.025	±0.025	<b>C</b>	±.0005	±.001	±.001
	<b>H</b>	±0.013	±0.025	±0.013	<b>H</b>	±.0005	±.0005	±.001
	<b>E</b>	±0.025	±0.025	±0.025	<b>E</b>	±.001	±.001	±.001
	<b>G</b>	±0.025	±0.13	±0.025	<b>G</b>	±.001	±.001	±.005
	<b>K</b>	±0.013	±0.025	±0.05-±0.13	<b>K</b>	±.0005	±.002-.005	±.001
	<b>M</b>	±0.08-±0.18	±0.13	±0.05-±0.13	<b>M</b>	±.002-.005	±.002-.005	±.005
	<b>U</b>	±0.13-±0.38	±0.13	±0.08-±0.25	<b>U</b>	±.005-.012	±.005-.010	±.005

2 Clearance Angle			
	A	20°	P
	B	25°	O
	C	30°	G
	D	0°	N
	E		
	F		

4 Standard, Chipbreaker					
	N		G		B
	R		W		H
	F		T		C
	A		Q		J
	M		U	Othe	X

5 Inscribed Circle Dia.									
ISO								ANSI	
C	D	R	S	T	V	W	mm	Code	IC Size
									inch
S4	04	03	03	06	-	-	3.97	(1.2)	5/32
04	05	04	04	08	08	S3	4.76	(1.5)	3/16
05	06	05	05	09	09	03	5.56	(1.8)	7/32
-	-	06	-	-	-	-	6	-	-
06	07	06	06	11	11	04	6.35	2	1/4
08	09	07	07	13	13	05	7.94	(2.5)	5/16
-	-	08	-	-	-	-	8	-	-
09	11	09	09	16	16	06	9.525	3	3/8
-	-	10	-	-	-	-	10	-	-
-	-	12	-	-	-	-	12	-	-
12	15	12	12	22	22	08	12.7	4	1/2
16	19	15	15	27	27	10	15.875	5	5/8
-	-	16	-	-	-	-	16	-	-
19	23	19	19	33	33	13	19.05	6	3/4
-	-	20	-	-	-	-	20	-	-
22	27	22	22	38	38	15	22.225	7	7/8
-	-	25	-	-	-	-	25	-	-
25	31	25	25	44	44	17	25.4	8	1
32	38	31	31	54	54	21	31.75	10	1-1/4
-	-	32	-	-	-	-	32	-	-



6 Thickness			
ISO		ANSI	
Code	Size	Code	Size
S	mm	S	inch
01	1.59	1	1/16
02	2.38	(1.5)	3/32
T2	2.78	-	-
03	3.18	2	1/8
T3	3.97	(2.5)	5/32
04	4.76	3	3/16
05	5.56	(3.5)	7/32
06	6.35	4	1/4
07	7.94	5	5/16
09	9.525	6	3/8

7 Nose radius			
ISO		ANSI	
Code	Size	Code	Size
Rε	mm	Rε	inch
00		00	.000
003	0.03	(0.1)	.001
01	0.1	(0.2)	.004
02	0.2	(0.5)	.008
04	0.4	1	1/64
08	0.8	2	1/32
12	1.2	3	3/64
16	1.6	4	1/16
20	2.0	5	5/64
24	2.4	6	3/32
28	2.8	7	7/64
32	3.2	8	1/8
M0		0	circular

8 Edges						
Code	1	2	3	4	6	8
notes	1 edge	2 edges	3 edges	4 edges	6 edges	8 edges

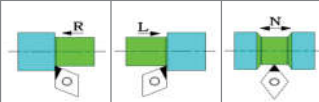
9 Cutting Direction			
Code	R	L	N
notes	R	L	N

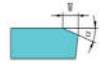
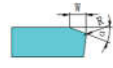











10 Cutting Edge Design			
E	T	S	F
Honed	Chamfered	Chamfered+Honed	Sharp Edge
			

11 Chamfered Width						
Code	000	005	010	015	020	030
Size	-	0.05	0.1	0.15	0.2	0.3

12 Chamfered Angle									
Code	$\alpha$	00	10	15	20	25	30	35	45
Size	°	-	10	15	20	25	30	35	45

13 Honed Size						
Code	00	02	05	10	20	30
Size	-	0.002	0.005	0.01	0.02	0.03

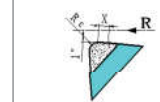
14 Type						
SF	SL	SS	CB	CS	SWW	SWU
Full Face	Solid Tipped Corner	Solid CBN	Standard Tipped Corners	Standard Full Edge	Solid Tipped Corners Type 'W'	Solid Tipped Corners Type 'U'
						

15 Cutting Edge Design		
ST	WG	CB
Nose Radius	Wiper	Chip Breaker
		

16 Cutting Edge Length						
Code	Ap	22	25	28	30	40
Size		2.2	2.5	2.8	3.0	4.0

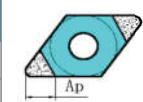

17 Surface Treatment			
S	Uncoated	C1	Coated
		R & D	

# Specifications of Mini PCBN Insert

**CC** 80° PCBN Negative Inserts



Sharp Cutting Edge	Standard Cutting Edge	Strong Cutting Edge
E0000005	S0101505	S0102510

Shape	ISO	Tip Shape	S				ANSI	Tip Shape	Dimensions in mm				
			PNS0115	PNS0119	PNS0121	PNS2019			ic	∅d	s	r	la
	CCGW060202-1NE0000005	CBST22S	●	●	●	●	CCGW2(1.5)(0.5)-1NE0000005	CBST22S	6.35	2.8	2.38	0.4	2.2
	-1NS0101505		●	●	●	●	-1NS0101505						
	-1NS0102510		●	●	●	●	-1NS0102510						
	CCGW060204-1NE0000005		●	●	●	●	CCGW2(1.5)1-1NE0000005						
	-1NS0101505		●	●	●	●	-1NS0101505						
	-1NS0102510		●	●	●	●	-1NS0102510						
	CCGW060208-1NE0000005		●	●	●	●	CCGW2(1.5)2-1NE0000005						
	-1NS0101505		●	●	●	●	-1NS0101505						
	-1NS0102510		●	●	●	●	-1NS0102510						
	CCGW060202-2NE0000005	CBST22S	●	●	●	●	CCGW2(1.5)(0.5)-2NE0000005	CBST22S	6.35	2.8	2.38	0.4	2.2
	-2NS0101505		●	●	●	●	-2NS0101505						
	-2NS0102510		●	●	●	●	-2NS0102510						
	CCGW060204-2NE0000005		●	●	●	●	CCGW2(1.5)1-2NE0000005						
	-2NS0101505		●	●	●	●	-2NS0101505						
	-2NS0102510		●	●	●	●	-2NS0102510						
	CCGW060208-2NE0000005		●	●	●	●	CCGW2(1.5)2-2NE0000005						
	-2NS0101505		●	●	●	●	-2NS0101505						
	-2NS0102510		●	●	●	●	-2NS0102510						

**CC** 80° PCBN Negative Inserts



Sharp Cutting Edge	Standard Cutting Edge	Strong Cutting Edge
E0000005	S0101505	S0102510

Shape	ISO	Tip Shape	S				ANSI	Tip Shape	Dimensions in mm				
			PNS0115	PNS0119	PNS0121	PNS2019			ic	∅d	s	r	la
	CCGW09T302-1NE0000005	CBST22S	●	●	●	●	CCGW3(2.5)(0.5)-1NE0000005	CBST22S	9.525	4.4	3.97	0.4	2.2
	-1NS0101505		●	●	●	●	-1NS0101505						
	-1NS0102510		●	●	●	●	-1NS0102510						
	CCGW09T304-1NE0000005		●	●	●	●	CCGW3(2.5)1-1NE0000005						
	-1NS0101505		●	●	●	●	-1NS0101505						
	-1NS0102510		●	●	●	●	-1NS0102510						
	CCGW09T308-1NE0000005		●	●	●	●	CCGW3(2.5)2-1NE0000005						
	-1NS0101505		●	●	●	●	-1NS0101505						
	-1NS0102510		●	●	●	●	-1NS0102510						
	CCGW09T302-2NE0000005	CBST22S	●	●	●	●	CCGW3(2.5)(0.5)-2NE0000005	CBST22S	9.525	4.4	3.97	0.4	2.2
	-2NS0101505		●	●	●	●	-2NS0101505						
	-2NS0102510		●	●	●	●	-2NS0102510						
	CCGW09T304-2NE0000005		●	●	●	●	CCGW3(2.5)1-2NE0000005						
	-2NS0101505		●	●	●	●	-2NS0101505						
	-2NS0102510		●	●	●	●	-2NS0102510						
	CCGW09T308-2NE0000005		●	●	●	●	CCGW3(2.5)2-2NE0000005						
	-2NS0101505		●	●	●	●	-2NS0101505						
	-2NS0102510		●	●	●	●	-2NS0102510						

Examples: ISO: CCGW060204-2NS0101505 CBST22S PNS0115  
 ANSI: CCGW2(1.5)-2NS0101505 CBST22S PNS0115

# Specifications of Mini PCBN Insert

**CC** 80° PCBN Negative Inserts



Sharp Cutting Edge	Standard Cutting Edge	Strong Cutting Edge
E0000005	S0101505	S0102510

Shape	ISO	Tip Shape	S				ANSI	Tip Shape	Dimensions in mm				
			PNS0115	PNS0119	PNS0121	PNS2019			ic	ød	s	r	la
	CCGW120402-1NE0000005	CBST22S	●	●	●	●	CCGW43(0.5)-1NE0000005	CBST22S	12.7	5.5	4.76	2.2	0.2
	-1NS0101505		●	●	●	●	-1NS0101505						0.4
	-1NS0102510		●	●	●	●	-1NS0102510						0.8
	CCGW120404-1NE0000005		●	●	●	●	CCGW431-1NE0000005						1.2
	-1NS0101505		●	●	●	●	-1NS0101505						
	-1NS0102510		●	●	●	●	-1NS0102510						
	CCGW120408-1NE0000005		●	●	●	●	CCGW432-1NE0000005						
	-1NS0101505		●	●	●	●	-1NS0101505						
	-1NS0102510		●	●	●	●	-1NS0102510						
	CCGW120412-1NE0000005		●	●	●	●	CCGW433-1NE0000005						
-1NS0101505	●	●	●	●	-1NS0101505								
-1NS0102510	●	●	●	●	-1NS0102510								
	CCGW120402-2NE0000005	CBST22S	●	●	●	●	CCGW43(0.5)-2NE0000005	CBST22S	12.7	5.5	4.76	2.2	0.2
	-2NS0101505		●	●	●	●	-2NS0101505						0.4
	-2NS0102510		●	●	●	●	-2NS0102510						0.8
	CCGW120404-2NE0000005		●	●	●	●	CCGW431-2NE0000005						1.2
	-2NS0101505		●	●	●	●	-2NS0101505						
	-2NS0102510		●	●	●	●	-2NS0102510						
	CCGW120408-2NE0000005		●	●	●	●	CCGW432-2NE0000005						
	-2NS0101505		●	●	●	●	-2NS0101505						
	-2NS0102510		●	●	●	●	-2NS0102510						
	CCGW120412-2NE0000005		●	●	●	●	CCGW433-2NE0000005						
-2NS0101505	●	●	●	●	-2NS0101505								
-2NS0102510	●	●	●	●	-2NS0102510								

Examples: ISO: CCGW120404-2NS0101505 CBST22S PNS0115  
 ANSI: CCGW431-2NS0101505 CBST22S PNS0115

# Specifications of Mini PCBN Insert

**DC** 55° PCBN Negative Inserts



Sharp Cutting Edge	Standard Cutting Edge	Strong Cutting Edge
E0000005	S0101505	S0102510

Shape	ISO	Tip Shape	S				ANSI	Tip Shape	Dimensions in mm				
			PNS0115	PNS0119	PNS0121	PNS2019			ic	Ød	s	r	la
	DCGW070202-1NE0000005	CBST22S	●	●	●	●	DCGW2(1.5)(0.5)-1NE0000005	CBST22S	6.35	2.8	2.38	0.4	2.2
	-1NS0101505		●	●	●	●	-1NS0101505						
	-1NS0102510		●	●	●	●	-1NS0102510						
	DCGW070204-1NE0000005		●	●	●	●	DCGW2(1.5)1-1NE0000005						
	-1NS0101505		●	●	●	●	-1NS0101505						
	-1NS0102510		●	●	●	●	-1NS0102510						
	DCGW070208-1NE0000005		●	●	●	●	DCGW2(1.5)2-1NE0000005						
	-1NS0101505		●	●	●	●	-1NS0101505						
	-1NS0102510		●	●	●	●	-1NS0102510						
	DCGW070202-2NE0000005	CBST22S	●	●	●	●	DCGW2(1.5)(0.5)-2NE0000005	CBST22S	6.35	2.8	2.38	0.4	2.2
	-2NS0101505		●	●	●	●	-2NS0101505						
	-2NS0102510		●	●	●	●	-2NS0102510						
	DCGW070204-2NE0000005		●	●	●	●	DCGW2(1.5)1-2NE0000005						
	-2NS0101505		●	●	●	●	-2NS0101505						
	-2NS0102510		●	●	●	●	-2NS0102510						
	DCGW070208-2NE0000005		●	●	●	●	DCGW2(1.5)2-2NE0000005						
	-2NS0101505		●	●	●	●	-2NS0101505						
	-2NS0102510		●	●	●	●	-2NS0102510						

**DC** 55° PCBN Negative Inserts



Sharp Cutting Edge	Standard Cutting Edge	Strong Cutting Edge
E0000005	S0101505	S0102510

Shape	ISO	Tip Shape	S				ANSI	Tip Shape	Dimensions in mm				
			PNS0115	PNS0119	PNS0121	PNS2019			ic	Ød	s	r	la
	DCGW11T302-1NE0000005	CBST22S	●	●	●	●	DCGW3(2.5)(0.5)-1NE0000005	CBST22S	9.525	4.4	3.97	0.2	2.2
	-1NS0101505		●	●	●	●	-1NS0101505						
	-1NS0102510		●	●	●	●	-1NS0102510						
	DCGW11T304-1NE0000005		●	●	●	●	DCGW3(2.5)1-1NE0000005						
	-1NS0101505		●	●	●	●	-1NS0101505						
	-1NS0102510		●	●	●	●	-1NS0102510						
	DCGW11T308-1NE0000005		●	●	●	●	DCGW3(2.5)2-1NE0000005						
	-1NS0101505		●	●	●	●	-1NS0101505						
	-1NS0102510		●	●	●	●	-1NS0102510						
	DCGW11T312-1NE0000005	CBST22S	●	●	●	●	DCGW3(2.5)3-1NE0000005	CBST22S	9.525	4.4	3.97	0.2	2.2
	-1NS0101505		●	●	●	●	-1NS0101505						
	-1NS0102510		●	●	●	●	-1NS0102510						
	DCGW11T302-2NE0000005		●	●	●	●	DCGW3(2.5)(0.5)-2NE0000005						
	-2NS0101505		●	●	●	●	-2NS0101505						
	-2NS0102510		●	●	●	●	-2NS0102510						
	DCGW11T304-2NE0000005		●	●	●	●	DCGW3(2.5)1-2NE0000005						
	-2NS0101505		●	●	●	●	-2NS0101505						
	-2NS0102510		●	●	●	●	-2NS0102510						
	DCGW11T308-2NE0000005	CBST22S	●	●	●	●	DCGW3(2.5)2-2NE0000005	CBST22S	9.525	4.4	3.97	0.4	2.2
	-2NS0101505		●	●	●	●	-2NS0101505						
	-2NS0102510		●	●	●	●	-2NS0102510						
	DCGW11T312-2NE0000005		●	●	●	●	DCGW3(2.5)3-2NE0000005						
	-2NS0101505		●	●	●	●	-2NS0101505						
	-2NS0102510		●	●	●	●	-2NS0102510						
	DCGW11T312-2NE0000005		●	●	●	●	DCGW3(2.5)3-2NE0000005						
	-2NS0101505		●	●	●	●	-2NS0101505						
	-2NS0102510		●	●	●	●	-2NS0102510						

Examples: ISO: DCGW11T304-2NS0101505 CBST22S PNS0115  
 ANSI: DCGW3(2.5)1-2NS0101505 CBST22S PNS0115

# Specifications of Mini PCBN Insert

**TP** 60° PCBN Negative Inserts



Sharp Cutting Edge	Standard Cutting Edge	Strong Cutting Edge
E0000005	S0101505	S0102510

Shape	ISO	Tip Shape	S				ANSI	Tip Shape	Dimensions in mm				
			PNS0115	PNS0119	PNS0121	PNS2019			ic	∅d	s	r	la
	TPGW080202-1NE0000005	CBST22S	●	●	●	●	TPGW(1.5)(1.5)(0.5)-1NE0000005	CBST22S	4.76	2.4	2.38	0.4	2.2
	-1NS0101505		●	●	●	●	-1NS0101505						
	-1NS0102510		●	●	●	●	-1NS0102510						
	TPGW080204-1NS0101005		●	●	●	●	TPGW(1.5)(1.5)1-1NS0101005						
	-1NS0101505		●	●	●	●	-1NS0101505						
	-1NS0102510		●	●	●	●	-1NS0102510						
	TPGW080202-3NE0000005	CBST22S	●	●	●	●	TPGW(1.5)(1.5)(0.5)-3NE0000005	CBST22S	4.76	2.4	2.38	0.4	2.2
	-3NS0102510		●	●	●	●	-3NS0101505						
	-3NS0152020		●	●	●	●	-3NS0102510						
	TPGW080204-3NE0000005		●	●	●	●	TPGW(1.5)(1.5)1-3NE0000005						
	-3NS0101505		●	●	●	●	-3NS0101505						
	-3NS0102510		●	●	●	●	-3NS0102510						

**TP** 60° PCBN Negative Inserts



Sharp Cutting Edge	Standard Cutting Edge	Strong Cutting Edge
E0000005	S0101505	S0102510

Shape	ISO	Tip Shape	S				ANSI	Tip Shape	Dimensions in mm				
			PNS0115	PNS0119	PNS0121	PNS2019			ic	∅d	s	r	la
	TPGW090202-1NE0000005	CBST22S	●	●	●	●	TPGW(1.8)(1.5)(0.5)-1NE0000005	CBST22S	5.56	2.8	2.38	0.4	2.2
	-1NS0101505		●	●	●	●	-1NS0101505						
	-1NS0102510		●	●	●	●	-1NS0102510						
	TPGW090204-1NE0000005		●	●	●	●	TPGW(1.8)(1.5)1-1NE0000005						
	-1NS0101505		●	●	●	●	-1NS0101505						
	-1NS0102510		●	●	●	●	-1NS0102510						
	TPGW090208-1NE0000005	CBST22S	●	●	●	●	TPGW(1.8)(1.5)2-1NE0000005	CBST22S	5.56	2.8	2.38	0.4	2.2
	-1NS0101505		●	●	●	●	-1NS0101505						
	-1NS0152020		●	●	●	●	-1NS0102510						
	TPGW090202-3NE0000005		●	●	●	●	TPGW(1.8)(1.5)(0.5)-3NE0000005						
	-3NS0101505		●	●	●	●	-3NS0101505						
	-3NS0102510		●	●	●	●	-3NS0102510						
	TPGW090204-3NE0000005	CBST22S	●	●	●	●	TPGW(1.8)(1.5)1-3NE0000005	CBST22S	5.56	2.8	2.38	0.4	2.2
	-3NS0101505		●	●	●	●	-3NS0101505						
	-3NS0102510		●	●	●	●	-3NS0102510						
	TPGW090208-3NE0000005		●	●	●	●	TPGW(1.8)(1.5)2-3NE0000005						
	-3NS0101505		●	●	●	●	-3NS0101505						
	-3NS0102510		●	●	●	●	-3NS0102510						

Examples: ISO: TPGW090204-3NS0101505 CBST22S PNS0115

ANSI: TPGW(1.8)(1.5)1-3NS0101505 CBST22S PNS0115

# Specifications of Mini PCBN Insert

**TP** 60° PCBN Negative Inserts



Sharp Cutting Edge	Standard Cutting Edge	Strong Cutting Edge
E0000005	S0101505	S0102510

Shape	ISO	Tip Shape	S				ANSI	Tip Shape	Dimensions in mm				
			PNS0115	PNS0119	PNS0121	PNS2019			ic	∅d	s	r	la
	TPGW110302-1NE0000005	CBST22S	●	●	●	●	TPGW22(0.5)-1NE0000005	CBST22S	6.35	3.3	3.18	0.4	2.2
	-1NS0101505		●	●	●	●	-1NS0101505						
	-1NS0102510		●	●	●	●	-1NS0102510						
	TPGW110304-1NE0000005		●	●	●	●	TPGW221-1NE0000005						
	-1NS0101505		●	●	●	●	-1NS0101505						
	-1NS0102510		●	●	●	●	-1NS0102510						
	TPGW110302-3NE0000005	CBST22S	●	●	●	●	TPGW22(0.5)-3NE0000005	CBST22S	6.35	3.3	3.18	0.4	2.2
	-3NS0101505		●	●	●	●	-3NS0101505						
	-3NS0102510		●	●	●	●	-3NS0102510						
	TPGW110304-3NE0000005		●	●	●	●	TPGW221-3NE0000005						
	-3NS0101505		●	●	●	●	-3NS0101505						
	-3NS0102510		●	●	●	●	-3NS0102510						

**TP** 60° PCBN Negative Inserts



Sharp Cutting Edge	Standard Cutting Edge	Strong Cutting Edge
E0000005	S0101505	S0102510

Shape	ISO	Tip Shape	S				ANSI	Tip Shape	Dimensions in mm				
			PNS0115	PNS0119	PNS0121	PNS2019			ic	∅d	s	r	la
	TPGW160302-1NE0000005	CBST22S	●	●	●	●	TPGW32(0.5)-1NE0000005	CBST22S	9.525	4.4	3.18	0.4	2.2
	-1NS0101505		●	●	●	●	-1NS0101505						
	-1NS0102510		●	●	●	●	-1NS0102510						
	TPGW160304-1NE0000005		●	●	●	●	TPGW321-1NE0000005						
	-1NS0101505		●	●	●	●	-1NS0101505						
	-1NS0102510		●	●	●	●	-1NS0102510						
	TPGW160308-1NE0000005	CBST22S	●	●	●	●	TPGW322-1NE0000005	CBST22S	9.525	4.4	3.18	0.4	2.2
	-1NS0101505		●	●	●	●	-1NS0101505						
	-1NS0102510		●	●	●	●	-1NS0102510						
	TPGW160302-3NE0000005		●	●	●	●	TPGW32(0.5)-3NE0000005						
	-3NS0101505		●	●	●	●	-3NS0101505						
	-3NS0102510		●	●	●	●	-3NS0102510						
	TPGW160304-3NE0000005	CBST22S	●	●	●	●	TPGW321-3NE0000005	CBST22S	9.525	4.4	3.18	0.4	2.2
	-3NS0101505		●	●	●	●	-3NS0101505						
	-3NS0102510		●	●	●	●	-3NS0102510						
	TPGW160308-3NE0000005		●	●	●	●	TPGW322-3NE0000005						
	-3NS0101505		●	●	●	●	-3NS0101505						
	-3NS0102510		●	●	●	●	-3NS0102510						

Examples: ISO: TPGW160304-3NS0101505 CBST22S PNS0115  
ANSI: TPGW321-3NS0101505 CBST22S PNS0115



# Specifications of Mini PCBN Insert

**TP** 60° PCBN Negative Inserts



Sharp Cutting Edge	Standard Cutting Edge	Strong Cutting Edge
E0000005	S0101505	S0102510

Shape	ISO	Tip Shape	S				ANSI	Tip Shape	Dimensions in mm					
			PNS0115	PNS0119	PNS0121	PNS2019			ic	ød	s	r	la	
	TPGW160402-1NE0000005	CBST22S	●	●	●	●	TPGW33(0.5)-1NE0000005	CBST22S	9.525	4.4	4.76	0.4	2.2	0.2
	-1NS0101505		●	●	●	●	-1NS0101505							0.8
	-1NS0102510		●	●	●	●	-1NS0102510							0.2
	TPGW160404-1NE0000005		●	●	●	●	TPGW331-1NE0000005							0.2
	-1NS0101505		●	●	●	●	-1NS0101505							0.4
	-1NS0102510		●	●	●	●	-1NS0102510							0.8
	TPGW160408-1NE0000005		●	●	●	●	TPGW332-1NE0000005							0.2
	-1NS0101505		●	●	●	●	-1NS0101505							0.4
	-1NS0102510		●	●	●	●	-1NS0102510							0.8
	TPGW160402-3NE0000005	CBST22S	●	●	●	●	TPGW33(0.5)-3NE0000005	CBST22S	9.525	4.4	4.76	0.4	2.2	0.2
	-3NS0101505		●	●	●	●	-3NS0101505							0.8
	-3NS0102510		●	●	●	●	-3NS0102510							0.2
	TPGW160404-3NE0000005		●	●	●	●	TPGW331-3NE0000005							0.2
	-3NS0101505		●	●	●	●	-3NS0101505							0.4
	-3NS0102510		●	●	●	●	-3NS0102510							0.8
	TPGW160408-3NE0000005		●	●	●	●	TPGW332-3NE0000005							0.2
	-3NS0101505		●	●	●	●	-3NS0101505							0.4
	-3NS0102510		●	●	●	●	-3NS0102510							0.8

Examples: ISO: TPGW160404-3NS0101505 CBST22S PNS0115  
 ANSI: TPGW331-3NS0101505 CBST22S PNS0115

# Specifications of Mini PCBN Insert

## VB 35° PCBN Negative Inserts



Sharp Cutting Edge	Standard Cutting Edge	Strong Cutting Edge
E0000005	S0101505	S0102510

Shape	ISO	Tip Shape	S				ANSI	Tip Shape	Dimensions in mm				
			PNS0115	PNS0119	PNS0121	PNS2019			ic	Ød	s	r	la
	VBGW110302-1NE0000005	CBST22S	●	●	●	●	VBGW22(0.5)-1NE0000005	CBST22S	6.35	2.8	3.18	0.4	2.2
	-1NS0101505		●	●	●	●	-1NS0101505						
	-1NS0102510		●	●	●	●	-1NS0102510						
	VBGW110304-1NE0000005		●	●	●	●	VBGW221-1NE0000005						
	-1NS0101505		●	●	●	●	-1NS0101505						
	-1NS0102510		●	●	●	●	-1NS0102510						
	VBGW110308-1NE0000005		●	●	●	●	VBGW222-1NE0000005						
	-1NS0101505		●	●	●	●	-1NS0101505						
	-1NS0102510		●	●	●	●	-1NS0102510						
	VBGW110302-2NE0000005	CBST22S	●	●	●	●	VBGW22(0.5)-2NE0000005	CBST22S	6.35	2.8	3.18	0.4	2.2
	-2NS0101505		●	●	●	●	-2NS0101505						
	-2NS0102510		●	●	●	●	-2NS0102510						
	VBGW110304-2NE0000005		●	●	●	●	VBGW221-2NE0000005						
	-2NS0101505		●	●	●	●	-2NS0101505						
	-2NS0102510		●	●	●	●	-2NS0102510						
	VBGW110308-2NE0000005		●	●	●	●	VBGW222-2NE0000005						
	-2NS0101505		●	●	●	●	-2NS0101505						
	-2NS0102510		●	●	●	●	-2NS0102510						

## VB 35° PCBN Negative Inserts



Sharp Cutting Edge	Standard Cutting Edge	Strong Cutting Edge
E0000005	S0101505	S0102510

Shape	ISO	Tip Shape	S				ANSI	Tip Shape	Dimensions in mm				
			PNS0115	PNS0119	PNS0121	PNS2019			ic	Ød	s	r	la
	VBGW160402-1NE0000005	CBST22S	●	●	●	●	VBGW33(0.5)-1NE0000005	CBST22S	9.525	4.4	4.76	0.2	2.2
	-1NS0101505		●	●	●	●	-1NS0101505						
	-1NS0102510		●	●	●	●	-1NS0102510						
	VBGW160404-1NE0000005		●	●	●	●	VBGW331-1NE0000005						
	-1NS0101505		●	●	●	●	-1NS0101505						
	-1NS0102510		●	●	●	●	-1NS0102510						
	VBGW160408-1NE0000005		●	●	●	●	VBGW332-1NE0000005						
	-1NS0101505		●	●	●	●	-1NS0101505						
	-1NS0102510		●	●	●	●	-1NS0102510						
VBGW160412-1NE0000005	●	●	●	●	VBGW333-1NE0000005								
-1NS0101505	●	●	●	●	-1NS0101505								
-1NS0102510	●	●	●	●	-1NS0102510								
	VBGW160402-2NE0000005	CBST22S	●	●	●	●	VBGW33(0.5)-2NE0000005	CBST22S	9.525	4.4	4.76	0.2	2.2
	-2NS0101505		●	●	●	●	-2NS0101505						
	-2NS0102510		●	●	●	●	-2NS0102510						
	VBGW160404-2NE0000005		●	●	●	●	VBGW331-2NE0000005						
	-2NS0101505		●	●	●	●	-2NS0101505						
	-2NS0102510		●	●	●	●	-2NS0102510						
	VBGW160408-2NE0000005		●	●	●	●	VBGW332-2NE0000005						
	-2NS0101505		●	●	●	●	-2NS0101505						
	-2NS0102510		●	●	●	●	-2NS0102510						
VBGW160412-2NE0000005	●	●	●	●	VBGW333-2NE0000005								
-2NS0101505	●	●	●	●	-2NS0101505								
-2NS0102510	●	●	●	●	-2NS0102510								

Examples: ISO: VBGW160404-2NS0101505 CBST22S PNS0115  
 ANSI: VBGW331-2NS0101505 CBST22S PNS0115

# Specifications of Mini PCBN Insert

**VC**

35° PCBN Negative Inserts



Sharp Cutting Edge	Standard Cutting Edge	Strong Cutting Edge
E0000005	S0101505	S0102510

Shape	ISO	Tip Shape	S				ANSI	Tip Shape	Dimensions in mm				
			PNS0115	PNS0119	PNS0121	PNS2019			ic	ød	s	r	la
	VCGW080202-1NE0000005	CBST22S	●	●	●	●	VCGW(1.5)(1.5)(0.5)-1NE0000005	CBST22S	4.76	2.2	2.38	0.4	2.2
	-1NS0101505		●	●	●	●	-1NS0101505						
	-1NS0102510		●	●	●	●	-1NS0102510						
	VCGW080204-1NE0000005		●	●	●	●	VCGW(1.5)(1.5)1-1NE0000005						
	-1NS0101505		●	●	●	●	-1NS0101505						
	-1NS0102510		●	●	●	●	-1NS0102510						
	VCGW080208-1NE0000005		●	●	●	●	VCGW(1.5)(1.5)2-1NE0000005						
	-1NS0101505		●	●	●	●	-1NS0101505						
	-1NS0102510		●	●	●	●	-1NS0102510						
	VCGW080202-2NE0000005	CBST22S	●	●	●	●	VCGW(1.5)(1.5)(0.5)-2NE0000005	CBST22S	4.76	2.2	2.38	0.4	2.2
	-2NS0101505		●	●	●	●	-2NS0101505						
	-2NS0102510		●	●	●	●	-2NS0102510						
	VCGW080204-2NE0000005		●	●	●	●	VCGW(1.5)(1.5)-2NE0000005						
	-2NS0101505		●	●	●	●	-2NS0101505						
	-2NS0102510		●	●	●	●	-2NS0102510						
	VCGW080208-2NE0000005		●	●	●	●	VCGW(1.5)(1.5)2-2NE0000005						
	-2NS0101505		●	●	●	●	-2NS0101505						
	-2NS0102510		●	●	●	●	-2NS0102510						

**VC**

35° PCBN Negative Inserts



Sharp Cutting Edge	Standard Cutting Edge	Strong Cutting Edge
E0000005	S0101505	S0102510

Shape	ISO	Tip Shape	S				ANSI	Tip Shape	Dimensions in mm				
			PNS0115	PNS0119	PNS0121	PNS2019			ic	ød	s	r	la
	VCGW110302-1NE0000005	CBST22S	●	●	●	●	VCGW22(0.5)-1NE0000005	CBST22S	6.35	2.8	3.18	0.4	2.2
	-1NS0101505		●	●	●	●	-1NS0101505						
	-1NS0102510		●	●	●	●	-1NS0102510						
	VCGW110304-1NE0000005		●	●	●	●	VCGW221-1NE0000005						
	-1NS0101505		●	●	●	●	-1NS0101505						
	-1NS0102510		●	●	●	●	-1NS0102510						
	VCGW110308-1NE0000005		●	●	●	●	VCGW222-1NE0000005						
	-1NS0101510		●	●	●	●	-1NS0101505						
	-1NS0102510		●	●	●	●	-1NS0102510						
	VCGW110302-2NE0000005	CBST22S	●	●	●	●	VCGW22(0.5)-2NE0000005	CBST22S	6.35	2.8	3.18	0.4	2.2
	-2NS0101505		●	●	●	●	-2NS0101505						
	-2NS0102510		●	●	●	●	-2NS0102510						
	VCGW110304-2NE0000005		●	●	●	●	VCGW221-2NE0000005						
	-2NS0101505		●	●	●	●	-2NS0101505						
	-2NS0102510		●	●	●	●	-2NS0102510						
	VCGW110308-2NE0000005		●	●	●	●	VCGW222-2NE0000005						
	-2NS0101505		●	●	●	●	-2NS0101505						
	-2NS0102510		●	●	●	●	-2NS0102510						

Examples: ISO: VCGW110304-2NS0101505 CBST22S PNS0115  
ANSI: VCGW221-2NS0101505 CBST22S PNS0115

# Specifications of Mini PCBN Insert

**VC** 35° PCBN Negative Inserts



Sharp Cutting Edge	Standard Cutting Edge	Strong Cutting Edge
E0000005	S0101505	S0102510

Shape	ISO	Tip Shape	S				ANSI	Tip Shape	Dimensions in mm				
			PNS0115	PNS0119	PNS0121	PNS2019			ic	ød	s	r	la
	VCGW160402-1NE0000005	CBST22S	●	●	●	●	VCGW33(0.5)-1NE0000005	CBST22S	9.525	4.4	4.76	0.4	2.2
	-1NS0101505		●	●	●	●	-1NS0101505						
	-1NS0102510		●	●	●	●	-1NS0102510						
	VCGW160404-1NE0000005		●	●	●	●	VCGW331-1NE0000005						
	-1NS0101505		●	●	●	●	-1NS0101505						
	-1NS0102510		●	●	●	●	-1NS0102510						
	VCGW160408-1NE0000005		●	●	●	●	VCGW332-1NE0000005						
	-1NS0101505		●	●	●	●	-1NS0101505						
	-1NS0102510		●	●	●	●	-1NS0102510						
	VCGW160402-2NE0000005	CBST22S	●	●	●	●	VCGW33(0.5)-2NE0000005	CBST22S	9.525	4.4	4.76	0.4	2.2
	-2NS0101505		●	●	●	●	-2NS0101505						
	-2NS0102510		●	●	●	●	-2NS0102510						
	VCGW160404-2NE0000005		●	●	●	●	VCGW331-2NE0000005						
	-2NS0101505		●	●	●	●	-2NS0101505						
	-2NS0102510		●	●	●	●	-2NS0102510						
	VCGW160408-2NE0000005		●	●	●	●	VCGW332-2NE0000005						
	-2NS0101505		●	●	●	●	-2NS0101505						
	-2NS0102510		●	●	●	●	-2NS0102510						

Examples: ISO: VCGW160404-2NS0101505 CBST22S PNS0115  
 ANSI: VCGW331-2NS0101505 CBST22S PNS0115

# Specifications of Mini PCBN Insert

**CN**

80° PCBN Negative Inserts

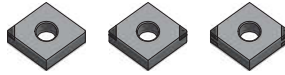

Sharp Cutting Edge	Standard Cutting Edge	Strong Cutting Edge
E000005	S0101505	S0102510

Shape	ISO	Tip Shape	S				ANSI	Tip Shape	Dimensions in mm				
			PNS0115	PNS0119	PNS0121	PNS2019			ic	ød	s	r	la
	CNGA 120402-1NE0000005	CBST22S	●	●	●	●	CNGA43(0.5)-1NE0000005	CBST22S	12.7	5.16	4.76	0.2	2.2
	-1NS0101505		●	●	●	●	-1NS0101510						
	-1NS0102510		●	●	●	●	-1NS0102510						
	CNGA 120404-1NE0000005		●	●	●	●	CNGA431-1NE0000005						
	-1NS0101505		●	●	●	●	-1NS0101505						
	-1NS0102510		●	●	●	●	-1NS0102510						
	CNGA 120408-1NE0000005		●	●	●	●	CNGA432-1NE0000005						
	-1NS0101505		●	●	●	●	-1NS0101505						
	-1NS0102510		●	●	●	●	-1NS0102510						
	CNGA 120412-1NE0000005		●	●	●	●	CNGA433-1NE0000005						
	-1NS0101510		●	●	●	●	-1NS0101505						
	-1NS0102510		●	●	●	●	-1NS0102510						
	CNGA 120402-2NE0000005	CBST22S	●	●	●	●	CNGA43(0.5)-2NE0000005	CBST22S	12.7	5.16	4.76	0.2	2.2
	-2NS0101505		●	●	●	●	-2NS0101505						
	-2NS0102510		●	●	●	●	-2NS0102510						
	CNGA 120404-2NE0000005		●	●	●	●	CNGA431-2NE0000005						
	-2NS0101505		●	●	●	●	-2NS0101505						
	-2NS0102510		●	●	●	●	-2NS0102510						
	CNGA 120408-2NE0000005		●	●	●	●	CNGA432-2NE0000005						
	-2NS0101505		●	●	●	●	-2NS0101505						
	-2NS0102510		●	●	●	●	-2NS0102510						
	CNGA 120412-2NE0000005		●	●	●	●	CNGA433-2NE0000005						
	-2NS0101505		●	●	●	●	-2NS0101505						
	-2NS0102510		●	●	●	●	-2NS0102510						
	CNGA 120402-4NE0000005	CBST22S	●	●	●	●	CNGA43(0.5)-4NE0000005	CBST22S	12.7	5.16	4.76	0.2	2.2
	-4NS0101505		●	●	●	●	-4NS0101505						
	-4NS0102510		●	●	●	●	-4NS0102510						
	CNGA 120404-4NE0000005		●	●	●	●	CNGA431-4NE0000005						
	-4NS0101505		●	●	●	●	-4NS0101505						
	-4NS0102510		●	●	●	●	-4NS0102510						
	CNGA 120408-4NE0000005		●	●	●	●	CNGA432-4NE0000005						
	-4NS0101505		●	●	●	●	-4NS0101505						
	-4NS0102510		●	●	●	●	-4NS0102510						
	CNGA 120412-4NE0000005		●	●	●	●	CNGA433-4NE0000005						
	-4NS0101505		●	●	●	●	-4NS0101505						
	-4NS0102510		●	●	●	●	-4NS0102510						

Examples: ISO: CNGA 120404-2NS0101505 CBST22S PNS0115  
 ANSI: CNGA431-2NS0101505 CBST22S PNS0115

# Specifications of Mini PCBN Insert

**DN**

55° PCBN Negative Inserts

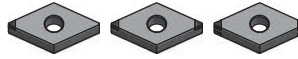

Sharp Cutting Edge	Standard Cutting Edge	Strong Cutting Edge
E0000005	S0101505	S0102510

Shape	ISO	Tip Shape	S				ANSI	Tip Shape	Dimensions in mm				
			PNS0115	PNS0119	PNS0121	PNS2019			ic	ød	s	r	la
	DNGA 150402-1NE0000005	CBST22S	●	●	●	●	DNGA43(0.5)-1NE0000005	CBST22S	12.7	5.16	4.76	2.2	0.2
	-1NS0101505		●	●	●	●	-1NS0101505						0.4
	-1NS0102510		●	●	●	●	-1NS0102510						0.8
	DNGA 150404-1NE0000005		●	●	●	●	DNGA431-1NE0000005						1.2
	-1NS0101505		●	●	●	●	-1NS0101505						
	-1NS0102510		●	●	●	●	-1NS0102510						
	DNGA 150408-1NE0000005		●	●	●	●	DNGA432-1NE0000005						
	-1NS0101505		●	●	●	●	-1NS0101505						
	-1NS0102510		●	●	●	●	-1NS0102510						
	DNGA 150412-1NE0000005		●	●	●	●	DNGA433-1NE0000005						
-1NS0101505	●	●	●	●	-1NS0101505								
-1NS0102510	●	●	●	●	-1NS0102510								
	DNGA 150402-2NE0000005	CBST22S	●	●	●	●	DNGA43(0.5)-2NE0000005	CBST22S	12.7	5.16	4.76	2.2	0.2
	-2NS0101505		●	●	●	●	-2NS0101505						0.4
	-2NS0102510		●	●	●	●	-2NS0102510						0.8
	DNGA 150404-2NE0000005		●	●	●	●	DNGA431-2NE0000005						1.2
	-2NS0101505		●	●	●	●	-2NS0101505						
	-2NS0102510		●	●	●	●	-2NS0102510						
	DNGA 150408-2NE0000005		●	●	●	●	DNGA432-2NE0000005						
	-2NS0101505		●	●	●	●	-2NS0101505						
	-2NS0102510		●	●	●	●	-2NS0102510						
	DNGA 150412-2NE0000005		●	●	●	●	DNGA433-2NE0000005						
-2NS0101505	●	●	●	●	-2NS0101505								
-2NS0102510	●	●	●	●	-2NS0102510								
	DNGA 150402-4NE0000005	CBST22S	●	●	●	●	DNGA43(0.5)-4NE0000005	CBST22S	12.7	5.16	4.76	2.2	0.2
	-4NS0101505		●	●	●	●	-4NS0101505						0.4
	-4NS0102510		●	●	●	●	-4NS0102510						0.8
	DNGA 150404-4NE0000005		●	●	●	●	DNGA431-4NE0000005						1.2
	-4NS0101505		●	●	●	●	-4NS0101505						
	-4NS0102510		●	●	●	●	-4NS0102510						
	DNGA 150408-4NE0000005		●	●	●	●	DNGA432-4NE0000005						
	-4NS0101505		●	●	●	●	-4NS0101505						
	-4NS0102510		●	●	●	●	-4NS0102510						
	DNGA 150412-4NE0000005		●	●	●	●	DNGA433-4NE0000005						
-4NS0101505	●	●	●	●	-4NS0101505								
-4NS0102510	●	●	●	●	-4NS0102510								

Examples: ISO: DNGA 150404-2NS0101505 CBST22S PNS0115  
 ANSI: DNGA431-2NS0101505 CBST22S PNS0115

# Specifications of Mini PCBN Insert

**DN**

55° PCBN Negative Inserts

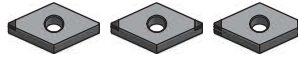

Sharp Cutting Edge	Standard Cutting Edge	Strong Cutting Edge
E000005	S0101505	S0102510

			S											
			PNS0115	PNS0119	PNS0121	PNS2019								
	DNGA 150602-1NE0000005	CBST22S	●	●	●	●	DNGA44(0.5)-1NE0000005	CBST22S	12.7	5.16	6.35	2.2		
	-1NS0101505		●	●	●	●	-1NS0101505							0.2
	-1NS0102510		●	●	●	●	-1NS0102510							0.4
	DNGA 150604-1NE0000005		●	●	●	●	DNGA441-1NE0000005							0.8
	-1NS0101505		●	●	●	●	-1NS0101505							1.2
	-1NS0102510		●	●	●	●	-1NS0102510							
	DNGA 150608-1NE0000005		●	●	●	●	DNGA442-1NE0000005							
	-1NS0101505		●	●	●	●	-1NS0101505							
	-1NS0102510		●	●	●	●	-1NS0102510							
	DNGA 150612-1NE0000005		●	●	●	●	DNGA443-1NE0000005							
	-1NS0101505		●	●	●	●	-1NS0101505							
	-1NS0102510		●	●	●	●	-1NS0102510							
	DNGA 150602-2NE0000005	CBST22S	●	●	●	●	DNGA44(0.5)-2NE0000005	CBST22S	12.7	5.16	6.35	2.2		
	-2NS0101505		●	●	●	●	-2NS0101505							0.2
	-2NS0102510		●	●	●	●	-2NS0102510							0.4
	DNGA 150604-2NE0000005		●	●	●	●	DNGA441-2NE0000005							0.8
	-2NS0101505		●	●	●	●	-2NS0101505							1.2
	-2NS0102510		●	●	●	●	-2NS0102510							
	DNGA 150608-2NE0000005		●	●	●	●	DNGA442-2NE0000005							
	-2NS0101505		●	●	●	●	-2NS0101505							
	-2NS0102510		●	●	●	●	-2NS0102510							
	DNGA 150612-2NE0000005		●	●	●	●	DNGA443-2NE0000005							
	-2NS0101505		●	●	●	●	-2NS0101505							
	-2NS0102510		●	●	●	●	-2NS0102510							
	DNGA 150602-4NE0000005	CBST22S	●	●	●	●	DNGA44(0.5)-4NE0000005	CBST22S	12.7	5.16	6.35	2.2		
	-4NS0101505		●	●	●	●	-4NS0101505							0.2
	-4NS0102510		●	●	●	●	-4NS0102510							0.4
	DNGA 150604-4NE0000005		●	●	●	●	DNGA441-4NE0000005							0.8
	-4NS0101505		●	●	●	●	-4NS0101505							1.2
	-4NS0102510		●	●	●	●	-4NS0102510							
	DNGA 150608-4NE0000005		●	●	●	●	DNGA442-4NE0000005							
	-4NS0101505		●	●	●	●	-4NS0101505							
	-4NS0102510		●	●	●	●	-4NS0102510							
	DNGA 150612-4NE0000005		●	●	●	●	DNGA443-4NE0000005							
	-4NS0101505		●	●	●	●	-4NS0101505							
	-4NS0102510		●	●	●	●	-4NS0102510							

Examples: ISO: DNGA 150604-2NS0101505 CBST22S PNS0115  
 ANSI: DNGA441-2NS0101505 CBST22S PNS0115

# Specifications of Mini PCBN Insert

**SN**

90° PCBN Negative Inserts



Sharp Cutting Edge	Standard Cutting Edge	Strong Cutting Edge
E000005	S0101505	S0102510

Shape	ISO	Tip Shape	S				ANSI	Tip Shape	Dimensions in mm				
			PNS0115	PNS0119	PNS0121	PNS2019			ic	ød	s	r	la
	SNGA 120402-1NE000005	CBST22S	●	●	●	●	SNGA43(0.5)-1NE000005	CBST22S	12.7	5.16	4.76	0.2	2.2
	-1NS0101505		●	●	●	●	-1NS0101505						
	-1NS0102510		●	●	●	●	-1NS0102510						
	SNGA 120404-1NE000005		●	●	●	●	SNGA431-1NE000005						
	-1NS0101505		●	●	●	●	-1NS0101505						
	-1NS0102510		●	●	●	●	-1NS0102510						
	SNGA 120408-1NE000005		●	●	●	●	SNGA432-1NE000005						
	-1NS0101505		●	●	●	●	-1NS0101505						
	-1NS0102510		●	●	●	●	-1NS0102510						
	SNGA 120412-1NE000005		●	●	●	●	SNGA433-1NE000005						
-1NS0101505	●	●	●	●	-1NS0101505								
-1NS0102510	●	●	●	●	-1NS0102510								
	SNGA 120402-4NE000005	CBST22S	●	●	●	●	SNGA43(0.5)-4NE000005	CBST22S	12.7	5.16	4.76	0.2	2.2
	-4NS0101505		●	●	●	●	-4NS0101505						
	-4NS0102510		●	●	●	●	-4NS0102510						
	SNGA 120404-4NE000005		●	●	●	●	SNGA431-4NE000005						
	-4NS0101505		●	●	●	●	-4NS0101505						
	-4NS0102510		●	●	●	●	-4NS0102510						
	SNGA 120408-4NE000005		●	●	●	●	SNGA432-4NE000005						
	-4NS0101505		●	●	●	●	-4NS0101505						
	-4NS0102510		●	●	●	●	-4NS0102510						
	SNGA 120412-4NE000005		●	●	●	●	SNGA433-4NE000005						
-4NS0101505	●	●	●	●	-4NS0101505								
-4NS0102510	●	●	●	●	-4NS0102510								
	SNGA 120402-8NE000005	CBST22S	●	●	●	●	SNGA43(0.5)-8NE000005	CBST22S	12.7	5.16	4.76	0.2	2.2
	-8NS0101505		●	●	●	●	-8NS0101505						
	-8NS0102510		●	●	●	●	-8NS0102510						
	SNGA 120404-8NE000005		●	●	●	●	SNGA431-8NE000005						
	-8NS0101505		●	●	●	●	-8NS0101505						
	-8NS0102510		●	●	●	●	-8NS0102510						
	SNGA 120408-8NE000005		●	●	●	●	SNGA432-8NE000005						
	-8NS0101505		●	●	●	●	-8NS0101505						
	-8NS0102510		●	●	●	●	-8NS0102510						
	SNGA 120412-8NE000005		●	●	●	●	SNGA433-8NE000005						
-8NS0101505	●	●	●	●	-8NS0101505								
-8NS0102510	●	●	●	●	-8NS0102510								

Examples: ISO: SNGA 120404-8NS0101505 CBST22S PNS0115  
 ANSI: SNGA431-8NS0101505 CBST22S PNS0115



# Specifications of Mini PCBN Insert

**SN**

90° PCBN Negative Inserts



Sharp Cutting Edge	Standard Cutting Edge	Strong Cutting Edge
E000005	S0101505	S0102510

Shape	ISO	Tip Shape	S				ANSI	Tip Shape	Dimensions in mm				
			PNS0115	PNS0119	PNS0121	PNS0119			ic	ød	s	r	la
	SNGN090402-1NE000005	CBST22S	●	●	●	●	SNGN33(0.5)-1NE000005	CBST22S	9.525	-	4.76	0.2	2.2
	-1NS0101505		●	●	●	●	-1NS0101505						
	-1NS0102510		●	●	●	●	-1NS0102510						
	SNGN090404-1NE000005		●	●	●	●	SNGN331-1NE000005						
	-1NS0101505		●	●	●	●	-1NS0101505						
	-1NS0102510		●	●	●	●	-1NS0102510						
	SNGN090408-1NE000005		●	●	●	●	SNGN332-1NE000005						
	-1NS0101505		●	●	●	●	-1NS0101505						
	-1NS0102510		●	●	●	●	-1NS0102510						
	SNGN090412-1NE000005		●	●	●	●	SNGN333-1NE000005						
-1NS0101505	●	●	●	●	-1NS0101505								
-1NS0102510	●	●	●	●	-1NS0102510								
	SNGN090402-4NE000005	CBST22S	●	●	●	●	SNGN33(0.5)-4NE000005	CBST22S	9.525	-	4.76	0.2	2.2
	-4NS0101505		●	●	●	●	-4NS0101505						
	-4NS0102510		●	●	●	●	-4NS0102510						
	SNGN090404-4NE000005		●	●	●	●	SNGN331-4NE000005						
	-4NS0101505		●	●	●	●	-4NS0101505						
	-4NS0102510		●	●	●	●	-4NS0102510						
	SNGN090408-4NE000005		●	●	●	●	SNGN332-4NE000005						
	-4NS0101505		●	●	●	●	-4NS0101505						
	-4NS0102510		●	●	●	●	-4NS0102510						
	SNGN090412-4NE000005		●	●	●	●	SNGN333-4NE000005						
-4NS0101505	●	●	●	●	-4NS0101505								
-4NS0102510	●	●	●	●	-4NS0102510								
	SNGN090402-8NE000005	CBST22S	●	●	●	●	SNGN33(0.5)-8NE000005	CBST22S	9.525	-	4.76	0.2	2.2
	-8NS0101505		●	●	●	●	-8NS0101505						
	-8NS0102510		●	●	●	●	-8NS0102510						
	SNGN090404-8NE000005		●	●	●	●	SNGN331-8NE000005						
	-8NS0101505		●	●	●	●	-8NS0101505						
	-8NS0102510		●	●	●	●	-8NS0102510						
	SNGN090408-8NE000005		●	●	●	●	SNGN332-8NE000005						
	-8NS0101505		●	●	●	●	-8NS0101505						
	-8NS0102510		●	●	●	●	-8NS0102510						
	SNGN090412-8NE000005		●	●	●	●	SNGN333-8NE000005						
-8NS0101505	●	●	●	●	-8NS0101505								
-8NS0102510	●	●	●	●	-8NS0102510								

Examples: ISO: SNGN090404-4NS0101505 CBST22S PNS0115  
 ANSI: SNGN332-2NS0101510 CBST22S PNS0115

# Specifications of Mini PCBN Insert

**TN** 60° PCBN Negative Inserts



Sharp Cutting Edge	Standard Cutting Edge	Strong Cutting Edge
E000005	S0101505	S0102510

Shape	ISO	Tip Shape	S				ANSI	Tip Shape	Dimensions in mm				
			PNS0115	PNS0119	PNS0121	PNS0119			ic	ød	s	r	la
	TNGA 160402-1NE0000005	CBST22S	●	●	●	●	TNGA33(0.5)-1NE0000005	CBST22S	9.525	3.81	4.76	2.2	0.2
	-1NS0101505		●	●	●	●	-1NS0101505						0.4
	-1NS0102510		●	●	●	●	-1NS0102510						0.8
	TNGA 160404-1NE0000005		●	●	●	●	TNGA331-1NE0000005						1.2
	-1NS0101505		●	●	●	●	-1NS0101505						
	-1NS0102510		●	●	●	●	-1NS0102510						
	TNGA 160408-1NE0000005		●	●	●	●	TNGA332-1NE0000005						
	-1NS0101505		●	●	●	●	-1NS0101505						
	-1NS0102510		●	●	●	●	-1NS0102510						
	TNGA 160412-1NE0000005		●	●	●	●	TNGA333-1NE0000005						
	-1NS0101505		●	●	●	●	-1NS0101505						
	-1NS0102510		●	●	●	●	-1NS0102510						
	TNGA 160402-3NE0000005	CBST22S	●	●	●	●	TNGA33(0.5)-3NE0000005	CBST22S	9.525	3.81	4.76	2.2	0.2
	-3NS0101505		●	●	●	●	-3NS0101505						0.4
	-3NS0102510		●	●	●	●	-3NS0102510						0.8
	TNGA 160404-3NE0000005		●	●	●	●	TNGA331-3NE0000005						1.2
	-3NS0101505		●	●	●	●	-3NS0101505						
	-3NS0102510		●	●	●	●	-3NS0102510						
	TNGA 160408-3NE0000005		●	●	●	●	TNGA332-3NE0000005						
	-3NS0101505		●	●	●	●	-3NS0101505						
	-3NS0102510		●	●	●	●	-3NS0102510						
	TNGA 160412-3NE0000005		●	●	●	●	TNGA333-3NE0000005						
	-3NS0101505		●	●	●	●	-3NS0101505						
	-3NS0102510		●	●	●	●	-3NS0102510						
	TNGA 160402-6NE0000005	CBST22S	●	●	●	●	TNGA33(0.5)-6NE0000005	CBST22S	9.525	3.81	4.76	2.2	0.2
	-6NS0101505		●	●	●	●	-6NS0101505						0.4
	-6NS0102510		●	●	●	●	-6NS0102510						0.8
	TNGA 160404-6NE0000005		●	●	●	●	TNGA331-6NE0000005						1.2
	-6NS0101505		●	●	●	●	-6NS0101505						
	-6NS0102510		●	●	●	●	-6NS0102510						
	TNGA 160408-6NE0000005		●	●	●	●	TNGA332-6NE0000005						
	-6NS0101505		●	●	●	●	-6NS0101510						
	-6NS0102510		●	●	●	●	-6NS0102510						
	TNGA 160412-6NE0000005		●	●	●	●	TNGA333-6NE0000005						
	-6NS0101505		●	●	●	●	-6NS0101505						
	-6NS0102510		●	●	●	●	-6NS0102510						

Examples: ISO: TNGA 160404-3NS0101505 CBST22S PNS0115  
 ANSI: TNGA331-3NS0101505 CBST22S PNS0115

# Specifications of Mini PCBN Insert



35° PCBN Negative Inserts

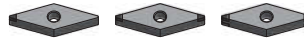

Sharp Cutting Edge	Standard Cutting Edge	Strong Cutting Edge
E000005	S0101505	S0102510

Shape	ISO	Tip Shape	S				ANSI	Tip Shape	Dimensions in mm				
			PNS0115	PNS0119	PNS0121	PNS2019			ic	ød	s	r	la
	VNGA 160402-1NE000005	CBST22S	●	●	●	●	VNGA33(0.5)-1NE000005	CBST22S	9.525	3.81	4.76	0.2	2.2
	-1NS0101505		●	●	●	●	-1NS0101505						
	-1NS0102510		●	●	●	●	-1NS0102510						
	VNGA 160404-1NE000005		●	●	●	●	VNGA331-1NE000005						
	-1NS0101505		●	●	●	●	-1NS0101505						
	-1NS0102510		●	●	●	●	-1NS0102510						
	VNGA 1604081NE000005		●	●	●	●	VNGA332-1NE000005						
	-1NS0101505		●	●	●	●	-1NS0101505						
	-1NS0102510		●	●	●	●	-1NS0102510						
	VNGA 160412-1NE000005		●	●	●	●	VNGA333-1NE000005						
-1NS0101505	●	●	●	●	-1NS0101505								
-1NS0102510	●	●	●	●	-1NS0102510								
	VNGA 160402-2NE000005	CBST22S	●	●	●	●	VNGA33(0.5)-2NE000005	CBST22S	9.525	3.81	4.76	0.2	2.2
	-2NS0101505		●	●	●	●	-2NS0101505						
	-2NS0102510		●	●	●	●	-2NS0102510						
	VNGA 160404-2NE000005		●	●	●	●	VNGA331-2NE000005						
	-2NS0101505		●	●	●	●	-2NS0101505						
	-2NS0102510		●	●	●	●	-2NS0102510						
	VNGA 160408-2NE000005		●	●	●	●	VNGA332-2NE000005						
	-2NS0101505		●	●	●	●	-2NS0101505						
	-2NS0102510		●	●	●	●	-2NS0102510						
	VNGA 160412-2NE000005		●	●	●	●	VNGA333-2NE000005						
-2NS0101505	●	●	●	●	-2NS0101505								
-2NS0102510	●	●	●	●	-2NS0102510								
	VNGA 160402-4NE000005	CBST22S	●	●	●	●	VNGA33(0.5)-4NE000005	CBST22S	9.525	3.81	4.76	0.2	2.2
	-4NS0101505		●	●	●	●	-4NS0101505						
	-4NS0102510		●	●	●	●	-4NS0102510						
	VNGA 160404-4NE000005		●	●	●	●	VNGA331-4NE000005						
	-4NS0101505		●	●	●	●	-4NS0101505						
	-4NS0102510		●	●	●	●	-4NS0102510						
	VNGA 160408-4NE000005		●	●	●	●	VNGA332-4NE000005						
	-4NS0101505		●	●	●	●	-4NS0101505						
	-4NS0102510		●	●	●	●	-4NS0102510						
	VNGA 160412-4NE000005		●	●	●	●	VNGA333-4NE000005						
-4NS0101505	●	●	●	●	-4NS0101505								
-4NS0102510	●	●	●	●	-4NS0102510								

Examples: ISO: VNGA 160404-2NS0101505 CBST22S PNS0115  
 ANSI: VNGA331-2NS0101505 CBST22S PNS0115

# Specifications of Mini PCBN Insert



80° PCBN Negative Inserts



Sharp Cutting Edge	Standard Cutting Edge	Strong Cutting Edge
E000005	S0101505	S0102510

Shape	ISO	Tip Shape	S				ANSI	Tip Shape	Dimensions in mm				
			PNS0115	PNS0119	PNS0121	PNS019			ic	ød	s	r	la
	WNGA080402-1NE0000005	CBST22S	●	●	●	●	WNGA43(0.5)-1NE0000005	CBST22S	12.7	5.16	4.76	0.2	2.2
	-1NS0101505		●	●	●	●	-1NS0101510						
	-1NS0102510		●	●	●	●	-1NS0102505						
	WNGA080404-1NE0000005		●	●	●	●	WNGA431-1NE0000005						
	-1NS0101505		●	●	●	●	-1NS0101505						
	-1NS0102510		●	●	●	●	-1NS0102510						
	WNGA080408-1NE0000005		●	●	●	●	WNGA432-1NE0000005						
	-1NS0101505		●	●	●	●	-1NS0101505						
	-1NS0102510		●	●	●	●	-1NS0102510						
	WNGA080412-1NE0000005		●	●	●	●	WNGA433-1NE0000005						
	-1NS0101505		●	●	●	●	-1NS0101505						
	-1NS0102510		●	●	●	●	-1NS0102510						
	WNGA080402-3NE0000005	CBST22S	●	●	●	●	WNGA43(0.5)-3NE0000005	CBST22S	12.7	5.16	4.76	0.2	2.2
	-3NS0101505		●	●	●	●	-3NS0101505						
	-3NS0102510		●	●	●	●	-3NS0102510						
	WNGA080404-3NE0000005		●	●	●	●	WNGA431-3NE0000005						
	-3NS0101505		●	●	●	●	-3NS0101505						
	-3NS0102510		●	●	●	●	-3NS0102510						
	WNGA080408-3NE0000005		●	●	●	●	WNGA432-3NE0000005						
	-3NS0101505		●	●	●	●	-3NS0101505						
	-3NS0102510		●	●	●	●	-3NS0102510						
	WNGA080412-3NE0000005		●	●	●	●	WNGA433-3NE0000005						
	-3NS0101505		●	●	●	●	-3NS0101505						
	-3NS0102510		●	●	●	●	-3NS0102510						
	WNGA080402-6NE0000005	CBST22S	●	●	●	●	WNGA43(0.5)-6NE0000005	CBST22S	12.7	5.16	4.76	0.2	2.2
	-6NS0101505		●	●	●	●	-6NS0101505						
	-6NS0102510		●	●	●	●	-6NS0102510						
	WNGA080404-6NE0000005		●	●	●	●	WNGA431-6NE0000005						
	-6NS0101505		●	●	●	●	-6NS0101505						
	-6NS0102510		●	●	●	●	-6NS0102510						
	WNGA080408-6NE0000005		●	●	●	●	WNGA432-6NE0000005						
	-6NS0101505		●	●	●	●	-6NS0101505						
	-6NS0102510		●	●	●	●	-6NS0102510						
	WNGA080412-6NE0000005		●	●	●	●	WNGA433-6NE0000005						
	-6NS0101505		●	●	●	●	-6NS0101505						
	-6NS0102510		●	●	●	●	-6NS0102510						

Examples: ISO: WNGA080404-6NS0101505 CBST22S PNS0115  
 ANSI: WNGA431-6NS0101505 CBST22S PNS0115SSS

# Specifications of Standard PCBN Insert

**CC** 80° PCBN Negative Inserts



Sharp Cutting Edge	Standard Cutting Edge	Strong Cutting Edge
E0000005	S0101505	S0102510

Shape	ISO	Tip Shape	S				ANSI	Tip Shape	Dimensions in mm				
			PNS0115	PNS0119	PNS0121	PNS2019			ic	∅d	s	r	la
	CCGW060202-1NE0000005	CBST30S	●	●	●	●	CCGW2(1.5)(0.5)-1NE0000005	CBST30S	6.35	2.8	2.38	0.4	3.0
	-1NS0101505		●	●	●	●	-1NS0101505						
	-1NS0102510		●	●	●	●	-1NS0102510						
	CCGW060204-1NE0000005		●	●	●	●	CCGW2(1.5)1-1NE0000005						
	-1NS0101505		●	●	●	●	-1NS0101505						
	-1NS0102510		●	●	●	●	-1NS0102510						
	CCGW060208-1NE0000005		●	●	●	●	CCGW2(1.5)2-1NE0000005						
	-1NS0101505		●	●	●	●	-1NS0101505						
	-1NS0102510		●	●	●	●	-1NS0102510						
	CCGW060202-2NE0000005	CBST30S	●	●	●	●	CCGW2(1.5)(0.5)-2NE0000005	CBST30S	6.35	2.8	2.38	0.4	3.0
	-2NS0101505		●	●	●	●	-2NS0101505						
	-2NS0102510		●	●	●	●	-2NS0102510						
	CCGW060204-2NE0000005		●	●	●	●	CCGW2(1.5)1-2NE0000005						
	-2NS0101505		●	●	●	●	-2NS0101505						
	-2NS0102510		●	●	●	●	-2NS0102510						
	CCGW060208-2NE0000005		●	●	●	●	CCGW2(1.5)2-2NE0000005						
	-2NS0101505		●	●	●	●	-2NS0101505						
	-2NS0102510		●	●	●	●	-2NS0102510						

**CC** 80° PCBN Negative Inserts



Sharp Cutting Edge	Standard Cutting Edge	Strong Cutting Edge
E0000005	S0101505	S0102510

Shape	ISO	Tip Shape	S				ANSI	Tip Shape	Dimensions in mm				
			PNS0115	PNS0119	PNS0121	PNS2019			ic	∅d	s	r	la
	CCGW09T302-1NE0000005	CBST30S	●	●	●	●	CCGW3(2.5)(0.5)-1NE0000005	CBST30S	9.525	4.4	3.97	0.4	3.0
	-1NS0101505		●	●	●	●	-1NS0101505						
	-1NS0102510		●	●	●	●	-1NS0102510						
	CCGW09T304-1NE0000005		●	●	●	●	CCGW3(2.5)1-1NE0000005						
	-1NS0101505		●	●	●	●	-1NS0101505						
	-1NS0102510		●	●	●	●	-1NS0102510						
	CCGW09T308-1NE0000005		●	●	●	●	CCGW3(2.5)2-1NE0000005						
	-1NS0101505		●	●	●	●	-1NS0101505						
	-1NS0102510		●	●	●	●	-1NS0102510						
	CCGW09T302-2NE0000005	CBST30S	●	●	●	●	CCGW3(2.5)(0.5)-2NE0000005	CBST30S	9.525	4.4	3.97	0.4	3.0
	-2NS0101505		●	●	●	●	-2NS0101505						
	-2NS0102510		●	●	●	●	-2NS0102510						
	CCGW09T304-2NE0000005		●	●	●	●	CCGW3(2.5)1-2NE0000005						
	-2NS0101505		●	●	●	●	-2NS0101505						
	-2NS0102510		●	●	●	●	-2NS0102510						
	CCGW09T308-2NE0000005		●	●	●	●	CCGW3(2.5)2-2NE0000005						
	-2NS0101505		●	●	●	●	-2NS0101505						
	-2NS0102510		●	●	●	●	-2NS0102510						

Examples: ISO: CCGW060204-2NS0101505 CBST30S PNS0115  
 ANSI: CCGW2(1.5)1-2NS0101505S CBST30S PNS0115

# Specifications of Standard PCBN Insert

**CC** 80° PCBN Negative Inserts



Sharp Cutting Edge	Standard Cutting Edge	Strong Cutting Edge
E0000005	S0101505	S0102510

Shape	ISO	Tip Shape	S				ANSI	Tip Shape	Dimensions in mm				
			PNS0115	PNS0119	PNS0121	PNS2019			ic	∅d	s	r	la
	CCGW120402-1NE0000005	CBST30S	●	●	●	●	CCGW43(0.5)-1NE0000005	CBST30S	12.7	5.5	4.76	3.0	0.2
	-1NS0101505		●	●	●	●	-1NS0101505						0.4
	-1NS0102510		●	●	●	●	-1NS0102510						0.8
	CCGW120404-1NE0000005		●	●	●	●	CCGW431-1NE0000005						1.2
	-1NS0101505		●	●	●	●	-1NS0101505						
	-1NS0102510		●	●	●	●	-1NS0102510						
	CCGW120408-1NE0000005		●	●	●	●	CCGW432-1NE0000005						
	-1NS0101505		●	●	●	●	-1NS0101505						
	-1NS0102510		●	●	●	●	-1NS0102510						
	CCGW120412-1NE0000005		●	●	●	●	CCGW433-1NE0000005						
-1NS0101505	●	●	●	●	-1NS0101505								
-1NS0102510	●	●	●	●	-1NS0102510								
	CCGW120402-2NE0000005	CBST30S	●	●	●	●	CCGW43(0.5)-2NE0000005	CBST30S	12.7	5.5	4.76	3.0	0.2
	-2NS0101505		●	●	●	●	-2NS0101505						0.4
	-2NS0102510		●	●	●	●	-2NS0102510						0.8
	CCGW120404-2NE0000005		●	●	●	●	CCGW431-2NE0000005						1.2
	-2NS0101505		●	●	●	●	-2NS0101505						
	-2NS0102510		●	●	●	●	-2NS0102510						
	CCGW120408-2NE0000005		●	●	●	●	CCGW432-2NE0000005						
	-2NS0101505		●	●	●	●	-2NS0101505						
	-2NS0102510		●	●	●	●	-2NS0102510						
	CCGW120412-2NE0000005		●	●	●	●	CCGW433-2NE0000005						
-2NS0101505	●	●	●	●	-2NS0101505								
-2NS0102510	●	●	●	●	-2NS0102510								

Examples: ISO: CCGW120404-2NS0101505 CBST30S PNS0115  
 ANSI: CCGW431-2NS0101505 CBST30S PNS0115

# Specifications of Standard PCBN Insert

**DC** 55° PCBN Negative Inserts



Sharp Cutting Edge	Standard Cutting Edge	Strong Cutting Edge
E0000005	S0101505	S0102510

			S										
			PNS0115	PNS0119	PNS0121	PNS2019							
	DCGW070202-1NE0000005	CBST30S	●	●	●	●	DCGW2(1.5)(0.5)-1NE0000005	CBST30S	6.35	2.8	2.38	0.4	3.0
	-1NS0101505		●	●	●	●	-1NS0101505						
	-1NS0102510		●	●	●	●	-1NS0102510						
	DCGW070204-1NE0000005		●	●	●	●	DCGW2(1.5)1-1NE0000005						
	-1NS0101505		●	●	●	●	-1NS0101505						
	-1NS0102510		●	●	●	●	-1NS0102510						
	DCGW070208-1NE0000005		●	●	●	●	DCGW2(1.5)2-1NE0000005						
	-1NS0101505		●	●	●	●	-1NS0101505						
	-1NS0102510		●	●	●	●	-1NS0102510						
	DCGW070202-2NE0000005	CBST30S	●	●	●	●	DCGW2(1.5)(0.5)-2NE0000005	CBST30S	6.35	2.8	2.38	0.4	3.0
	-2NS0101505		●	●	●	●	-2NS0101505						
	-2NS0102510		●	●	●	●	-2NS0102510						
	DCGW070204-2NE0000005		●	●	●	●	DCGW2(1.5)1-2NE0000005						
	-2NS0101505		●	●	●	●	-2NS0101505						
	-2NS0102510		●	●	●	●	-2NS0102510						
	DCGW070208-2NE0000005		●	●	●	●	DCGW2(1.5)2-2NE0000005						
	-2NS0101505		●	●	●	●	-2NS0101505						
	-2NS0102510		●	●	●	●	-2NS0102510						

**DC** 55° PCBN Negative Inserts

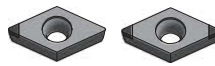

Sharp Cutting Edge	Standard Cutting Edge	Strong Cutting Edge
E0000005	S0101505	S0102510

			S										
			PNS0115	PNS0119	PNS0121	PNS2019							
	DCGW11T302-1NE0000005	CBST30S	●	●	●	●	DCGW3(2.5)(0.5)-1NE0000005	CBST30S	9.525	4.4	3.97	0.2	3.0
	-1NS0101505		●	●	●	●	-1NS0101505						
	-1NS0102510		●	●	●	●	-1NS0102510						
	DCGW11T304-1NE0000005		●	●	●	●	DCGW3(2.5)1-1NE0000005						
	-1NS0101505		●	●	●	●	-1NS0101505						
	-1NS0102510		●	●	●	●	-1NS0102510						
	DCGW11T308-1NE0000005		●	●	●	●	DCGW3(2.5)2-1NE0000005						
	-1NS0101505		●	●	●	●	-1NS0101505						
	-1NS0102510		●	●	●	●	-1NS0102510						
	DCGW11T312-1NE0000005	CBST30S	●	●	●	●	DCGW3(2.5)3-1NE0000005	CBST30S	9.525	4.4	3.97	0.2	3.0
	-1NS0101505		●	●	●	●	-1NS0101505						
	-1NS0102510		●	●	●	●	-1NS0102510						
	DCGW11T302-2NE0000005		●	●	●	●	DCGW3(2.5)(0.5)-2NE0000005						
	-2NS0101505		●	●	●	●	-2NS0101505						
	-2NS0102510		●	●	●	●	-2NS0102510						
	DCGW11T304-2NE0000005		●	●	●	●	DCGW3(2.5)1-2NE0000005						
	-2NS0101505		●	●	●	●	-2NS0101505						
	-2NS0102510		●	●	●	●	-2NS0102510						
	DCGW11T308-2NE0000005	CBST30S	●	●	●	●	DCGW3(2.5)2-2NE0000005	CBST30S	9.525	4.4	3.97	0.4	3.0
	-2NS0101505		●	●	●	●	-2NS0101505						
	-2NS0102510		●	●	●	●	-2NS0102510						
	DCGW11T312-2NE0000005		●	●	●	●	DCGW3(2.5)3-2NE0000005						
	-2NS0101505		●	●	●	●	-2NS0101505						
	-2NS0102510		●	●	●	●	-2NS0102510						
	DCGW11T302-2NE0000005		●	●	●	●	DCGW3(2.5)(0.5)-2NE0000005						
	-2NS0101505		●	●	●	●	-2NS0101505						
	-2NS0102510		●	●	●	●	-2NS0102510						

Examples: ISO: DCGW11T304-2NS0101505 CBST30S PNS0115  
 ANSI: DCGW3(2.5)1-2NS0101505 CBST30S PNS0115

# Specifications of Standard PCBN Insert

**TP** 60° PCBN Negative Inserts



Sharp Cutting Edge	Standard Cutting Edge	Strong Cutting Edge
E0000005	S0101505	S0102510

			K												
			PNK0117	PNK0119	PNK0121	PNK3017									
	TPGW080202-1NE0000005	CBST30S	●	●	●	●	TPGW(1.5)(1.5)(0.5)-1NE0000005	CBST30S	4.76	2.4	2.38	0.4	3.0	0.2	
	-1NS0101505		●	●	●	●	-1NS0101505								
	-1NS0102510		●	●	●	●	-1NS0102510								
	TPGW080204-1NE0000005		●	●	●	●	TPGW(1.5)(1.5)1-1NE0000005								
	-1NS0101505		●	●	●	●	-1NS0101505								
	-1NS0102510		●	●	●	●	-1NS0102510								
	TPGW080202-3NE0000005	CBST30S	●	●	●	●	TPGW(1.5)(1.5)(0.5)-3NE0000005	CBST30S	4.76	2.4	2.38	0.4	3.0	0.2	
	-3NS0101505		●	●	●	●	-3NS0101505								
	-3NS0102510		●	●	●	●	-3NS0102510								
	TPGW080204-3NE0000005		●	●	●	●	TPGW(1.5)(1.5)1-3NE0000005								
	-3NS0101505		●	●	●	●	-3NS0101505								
	-3NS0102510		●	●	●	●	-3NS0102510								

**TP** 60° PCBN Negative Inserts



Sharp Cutting Edge	Standard Cutting Edge	Strong Cutting Edge
E0000005	S0101505	S0102510

			S												
			PNS0115	PNS0119	PNS0121	PNS2019									
	TPGW090202-1NE0000005	CBST30S	●	●	●	●	TPGW(1.8)(1.5)(0.5)-1NE0000005	CBST30S	5.56	2.8	2.38	0.4	3.0	0.2	
	-1NS0101505		●	●	●	●	-1NS0101505								
	-1NS0102510		●	●	●	●	-1NS0102510								
	TPGW090204-1NE0000005		●	●	●	●	TPGW(1.8)(1.5)1-1NE0000005								
	-1NS0101505		●	●	●	●	-1NS0101505								
	-1NS0102510		●	●	●	●	-1NS0102510								
	TPGW090208-1NE0000005	CBST30S	●	●	●	●	TPGW(1.8)(1.5)2-1NE0000005	CBST30S	5.56	2.8	2.38	0.4	3.0	0.8	
	-1NS0101505		●	●	●	●	-1NS0101505								
	-1NS0102510		●	●	●	●	-1NS0102510								
	TPGW090204-3NE0000005		●	●	●	●	TPGW(1.8)(1.5)1-3NE0000005								
	-3NS0101505		●	●	●	●	-3NS0101505								
	-3NS0102510		●	●	●	●	-3NS0102510								
	TPGW090202-3NE0000005	CBST30S	●	●	●	●	TPGW(1.8)(1.5)(0.5)-3NE0000005	CBST30S	5.56	2.8	2.38	0.4	3.0	0.2	
	-3NS0101505		●	●	●	●	-3NS0101505								
	-3NS0102510		●	●	●	●	-3NS0102510								
	TPGW090204-3NE0000005		●	●	●	●	TPGW(1.8)(1.5)1-3NE0000005								
	-3NS0101505		●	●	●	●	-3NS0101505								
	-3NS0102510		●	●	●	●	-3NS0102510								
	TPGW090208-3NE0000005	CBST30S	●	●	●	●	TPGW(1.8)(1.5)2-3NE0000005	CBST30S	5.56	2.8	2.38	0.4	3.0	0.8	
	-3NS0101505		●	●	●	●	-3NS0101505								
	-3NS0102510		●	●	●	●	-3NS0102510								

Examples: ISO: TPGW090204-3NS0101505 CBST30S PNS0115  
 ANSI: TPGW(1.8)(1.5)1SSSSS-3NS0101505 CBST30S PNS0115



# Specifications of Standard PCBN Insert

**TP** 60° PCBN Negative Inserts



Sharp Cutting Edge	Standard Cutting Edge	Strong Cutting Edge
E0000005	S0101505	S0102510

Shape	ISO	Tip Shape	S				ANSI	Tip Shape	Dimensions in mm					
			PNS0115	PNS0119	PNS0121	PNS2019			ic	∅d	s	r	la	
	TPGW110302-1NE0000005	CBST30S	●	●	●	●	TPGW22(0.5)-1NE0000005	CBST30S	6.35	3.3	3.18	0.4	3.0	0.2
	-1NS0101505		●	●	●	●	-1NS0101505							0.2
	-1NS0102510		●	●	●	●	-1NS0102510							0.2
	TPGW110304-1NE0000005		●	●	●	●	TPGW221-1NE0000005							0.2
	-1NS0101505		●	●	●	●	-1NS0101505							0.2
	-1NS0102510		●	●	●	●	-1NS0102510							0.2
	TPGW110302-3NE0000005	CBST30S	●	●	●	●	TPGW22(0.5)-3NE0000005	CBST30S	6.35	3.3	3.18	0.4	3.0	0.2
	-3NS0101505		●	●	●	●	-3NS0101505							0.2
	-3NS0102510		●	●	●	●	-3NS0102510							0.2
	TPGW110304-3NE0000005		●	●	●	●	TPGW221-3NE0000005							0.2
	-3NS0101505		●	●	●	●	-3NS0101505							0.2
	-3NS0102510		●	●	●	●	-3NS0102510							0.2

**TP** 60° PCBN Negative Inserts



Sharp Cutting Edge	Standard Cutting Edge	Strong Cutting Edge
E0000005	S0101505	S0102510

Shape	ISO	Tip Shape	S				ANSI	Tip Shape	Dimensions in mm					
			PNS0115	PNS0119	PNS0121	PNS2019			ic	∅d	s	r	la	
	TPGW160302-1NE0000005	CBST30S	●	●	●	●	TPGW32(0.5)-1NE0000005	CBST30S	9.525	4.4	3.18	0.4	3.0	0.2
	-1NS0101505		●	●	●	●	-1NS0101505							0.2
	-1NS0102510		●	●	●	●	-1NS0102510							0.2
	TPGW160304-1NE0000005		●	●	●	●	TPGW321-1NE0000005							0.2
	-1NS0101505		●	●	●	●	-1NS0101505							0.2
	-1NS0102510		●	●	●	●	-1NS0102510							0.2
	TPGW160308-1NE0000005	CBST30S	●	●	●	●	TPGW322-1NE0000005	CBST30S	9.525	4.4	3.18	0.4	3.0	0.8
	-1NS0101505		●	●	●	●	-1NS0101505							0.8
	-1NS0102510		●	●	●	●	-1NS0102510							0.8
	TPGW160302-3NE0000005		●	●	●	●	TPGW32(0.5)-3NE0000005							0.2
	-3NS0101505		●	●	●	●	-3NS0101505							0.2
	-3NS0102510		●	●	●	●	-3NS0102510							0.2
	TPGW160304-3NE0000005	CBST30S	●	●	●	●	TPGW321-3NE0000005	CBST30S	9.525	4.4	3.18	0.4	3.0	0.2
	-3NS0101505		●	●	●	●	-3NS0101505							0.2
	-3NS0102510		●	●	●	●	-3NS0102510							0.2
	TPGW160308-3NE0000005		●	●	●	●	TPGW322-3NE0000005							0.2
	-3NS0101505		●	●	●	●	-3NS0101505							0.2
	-3NS0102510		●	●	●	●	-3NS0102510							0.2

Examples: ISO: TPGW160304-3NS0101505 CBST30S PNS0115  
ANSI: TPGW321-3NS0101505 CBST30S PNS0115

# Specifications of Standard PCBN Insert

**TP** 60° PCBN Negative Inserts



Sharp Cutting Edge	Standard Cutting Edge	Strong Cutting Edge
E0000005	S0101505	S0102510

Shape	ISO	Tip Shape	S				ANSI	Tip Shape	Dimensions in mm				
			PNS0115	PNS0119	PNS0121	PNS2019			ic	∅d	s	r	la
	TPGW160402-1NE0000005	CBST30S	●	●	●	●	TPGW33(0.5)-1NE0000005	CBST30S	9.525	4.4	4.76	0.4	3.0
	-1NS0101505		●	●	●	●	-1NS0101505						
	-1NS0102510		●	●	●	●	-1NS0102510						
	TPGW160404-1NE0000005		●	●	●	●	TPGW331-1NE0000005						
	-1NS0101505		●	●	●	●	-1NS0101505						
	-1NS0102510		●	●	●	●	-1NS0102510						
	TPGW160408-1NE0000005		●	●	●	●	TPGW332-1NE0000005						
	-1NS0101505		●	●	●	●	-1NS0101505						
	-1NS0102510		●	●	●	●	-1NS0102510						
	TPGW160402-3NE0000005	CBST30S	●	●	●	●	TPGW33(0.5)-3NE0000005	CBST30S	9.525	4.4	4.76	0.4	3.0
	-3NS0101505		●	●	●	●	-3NS0101505						
	-3NS0102510		●	●	●	●	-3NS0102510						
	TPGW160404-3NE0000005		●	●	●	●	TPGW331-3NE0000005						
	-3NS0101505		●	●	●	●	-3NS0101505						
	-3NS0102510		●	●	●	●	-3NS0102510						
	TPGW160408-3NE0000005		●	●	●	●	TPGW332-3NE0000005						
	-3NS0101505		●	●	●	●	-3NS0101505						
	-3NS0102510		●	●	●	●	-3NS0102510						

Examples: ISO: TPGW160404-3NS0101505 CBST30S PNS0115  
 ANSI: TPGW331-3NS0101505 CBST30S PNS0115

# Specifications of Standard PCBN Insert

## VB 35° PCBN Negative Inserts



Sharp Cutting Edge	Standard Cutting Edge	Strong Cutting Edge
E0000005	S0101505	S0102510

Shape	ISO	Tip Shape	S				ANSI	Tip Shape	Dimensions in mm				
			PNS0115	PNS0119	PNS0121	PNS2019			ic	Ød	s	r	la
	VBGW110302-1NE0000005	CBST30S	●	●	●	●	VBGW22(0.5)-1NE0000005	CBST30S	6.35	2.8	3.18	0.4	3.0
	-1NS0101505		●	●	●	●	-1NS0101505						
	-1NS0102510		●	●	●	●	-1NS0102510						
	VBGW110304-1NE0000005		●	●	●	●	VBGW221-1NE0000005						
	-1NS0101505		●	●	●	●	-1NS0101505						
	-1NS0102510		●	●	●	●	-1NS0102510						
	VBGW110308-1NE0000005		●	●	●	●	VBGW222-1NE0000005						
	-1NS0101505		●	●	●	●	-1NS0101505						
	-1NS0102510		●	●	●	●	-1NS0102510						
	VBGW110302-2NE0000005	CBST30S	●	●	●	●	VBGW22(0.5)-2NE0000005	CBST30S	6.35	2.8	3.18	0.4	3.0
	-2NS0101505		●	●	●	●	-2NS0101505						
	-2NS0102510		●	●	●	●	-2NS0102510						
	VBGW110304-2NE0000005		●	●	●	●	VBGW221-2NE0000005						
	-2NS0101505		●	●	●	●	-2NS0101505						
	-2NS0102510		●	●	●	●	-2NS0102510						
	VBGW110308-2NE0000005		●	●	●	●	VBGW222-2NE0000005						
	-2NS0101505		●	●	●	●	-2NS0101505						
	-2NS0102510		●	●	●	●	-2NS0102510						

## VB 35° PCBN Negative Inserts



Sharp Cutting Edge	Standard Cutting Edge	Strong Cutting Edge
E0000005	S0101505	S0102510

Shape	ISO	Tip Shape	S				ANSI	Tip Shape	Dimensions in mm				
			PNS0115	PNS0119	PNS0121	PNS2019			ic	Ød	s	r	la
	VBGW160402-1NE0000005	CBST30S	●	●	●	●	VBGW33(0.5)-1NE0000005	CBST30S	9.525	4.4	4.76	0.2	3.0
	-1NS0101505		●	●	●	●	-1NS0101505						
	-1NS0102510		●	●	●	●	-1NS0102510						
	VBGW160404-1NE0000005		●	●	●	●	VBGW331-1NE0000005						
	-1NS0101505		●	●	●	●	-1NS0101505						
	-1NS0102510		●	●	●	●	-1NS0102510						
	VBGW160408-1NE0000005		●	●	●	●	VBGW332-1NE0000005						
	-1NS0101505		●	●	●	●	-1NS0101505						
	-1NS0102510		●	●	●	●	-1NS0102510						
	VBGW160412-1NE0000005	CBST30S	●	●	●	●	VBGW333-1NE0000005	CBST30S	9.525	4.4	4.76	0.2	3.0
	-1NS0101505		●	●	●	●	-1NS0101505						
	-1NS0102510		●	●	●	●	-1NS0102510						
	VBGW160402-2NE0000005		●	●	●	●	VBGW33(0.5)-2NE0000005						
	-2NS0101505		●	●	●	●	-2NS0101505						
	-2NS0102510		●	●	●	●	-2NS0102510						
	VBGW160404-2NE0000005		●	●	●	●	VBGW331-2NE0000005						
	-2NS0101505		●	●	●	●	-2NS0101505						
	-2NS0102510		●	●	●	●	-2NS0102510						
	VBGW160408-2NE0000005	CBST30S	●	●	●	●	VBGW332-2NE0000005	CBST30S	9.525	4.4	4.76	0.4	3.0
	-2NS0101505		●	●	●	●	-2NS0101505						
	-2NS0102510		●	●	●	●	-2NS0102510						
	VBGW160412-2NE0000005		●	●	●	●	VBGW333-2NE0000005						
	-2NS0101505		●	●	●	●	-2NS0101505						
	-2NS0102510		●	●	●	●	-2NS0102510						
	VBGW160412-2NE0000005		●	●	●	●	VBGW333-2NE0000005						
	-2NS0101505		●	●	●	●	-2NS0101505						
	-2NS0102510		●	●	●	●	-2NS0102510						

Examples: ISO: VBGW160404-2NS0101505 CBST30S PNS0115  
ANSI: VBGW331-2NS0101505 CBST30S PNS0115

# Specifications of Standard PCBN Insert

## VC 35° PCBN Negative Inserts



Sharp Cutting Edge	Standard Cutting Edge	Strong Cutting Edge
E0000005	S0101505	S0102510

Shape	ISO	Tip Shape	S				ANSI	Tip Shape	Dimensions in mm				
			PNS0115	PNS0119	PNS0121	PNS2019			ic	ød	s	r	la
	VCGW080202-1NE0000005	CBST30S	●	●	●	●	VCGW(1.5)(1.5)(0.5)-1NE0000005	CBST30S	4.76	2.2	2.38	0.4	3.0
	-1NS0101505		●	●	●	●	-1NS0101505						
	-1NS0102510		●	●	●	●	-1NS0102510						
	VCGW080204-1NE0000005		●	●	●	●	VCGW(1.5)(1.5)1-1NE0000005						
	-1NS0101505		●	●	●	●	-1NS0101510						
	-1NS0102510		●	●	●	●	-1NS0102510						
	VCGW080208-1NE0000005		●	●	●	●	VCGW(1.5)(1.5)2-1NE0000005						
	-1NS0101505		●	●	●	●	-1NS0101505						
	-1NS0102510		●	●	●	●	-1NS0102510						
	VCGW080202-2NE0000005	CBST30S	●	●	●	●	VCGW(1.5)(1.5)(0.5)-2NE0000005	CBST30S	4.76	2.2	2.38	0.4	3.0
	-2NS0101505		●	●	●	●	-2NS0101505						
	-2NS0102510		●	●	●	●	-2NS0102510						
	VCGW080204-2NE0000005		●	●	●	●	VCGW(1.5)(1.5)-2NS0101005						
	-2NS0101505		●	●	●	●	-2NS0101510						
	-2NS0102510		●	●	●	●	-2NS0102510						
	VCGW080208-2NE0000005		●	●	●	●	VCGW(1.5)(1.5)2-2NE0000005						
	-2NS0101505		●	●	●	●	-2NS0101505						
	-2NS0102510		●	●	●	●	-2NS0102510						

## VC 35° PCBN Negative Inserts



Sharp Cutting Edge	Standard Cutting Edge	Strong Cutting Edge
E0000005	S0101505	S0102510

Shape	ISO	Tip Shape	S				ANSI	Tip Shape	Dimensions in mm				
			PNS0115	PNS0119	PNS0121	PNS2019			ic	ød	s	r	la
	VCGW110302-1NE0000005	CBST30S	●	●	●	●	VCGW22(0.5)-1NE0000005	CBST30S	6.35	2.8	3.18	0.4	3.0
	-1NS0101505		●	●	●	●	-1NS0101505						
	-1NS0102510		●	●	●	●	-1NS0102510						
	VCGW110304-1NE0000005		●	●	●	●	VCGW221-1NE0000005						
	-1NS0101505		●	●	●	●	-1NS0101505						
	-1NS0102510		●	●	●	●	-1NS0102510						
	VCGW110308-1NE0000005		●	●	●	●	VCGW222-1NE0000005						
	-1NS0101505		●	●	●	●	-1NS0101505						
	-1NS0102510		●	●	●	●	-1NS0102510						
	VCGW110302-2NE0000005	CBST30S	●	●	●	●	VCGW22(0.5)-2NE0000005	CBST30S	6.35	2.8	3.18	0.4	3.0
	-2NS0101505		●	●	●	●	-2NS0101505						
	-2NS0102510		●	●	●	●	-2NS0102510						
	VCGW110304-2NE0000005		●	●	●	●	VCGW221-2NE0000005						
	-2NS0101505		●	●	●	●	-2NS0101505						
	-2NS0102510		●	●	●	●	-2NS0102510						
	VCGW110308-2NE0000005		●	●	●	●	VCGW222-2NE0000005						
	-2NS0101505		●	●	●	●	-2NS0101505						
	-2NS0102510		●	●	●	●	-2NS0102510						

Examples: ISO: VCGW110304-2NS0101505 CBST30S PNS0115  
ANSI: VCGW221-2NS0101505 CBST30S PNS0115

# Specifications of Standard PCBN Insert

**VC** 35° PCBN Negative Inserts



Sharp Cutting Edge	Standard Cutting Edge	Strong Cutting Edge
E0000005	S0101505	S0102510

Shape	ISO	Tip Shape	S				ANSI	Tip Shape	Dimensions in mm				
			PNS0115	PNS0119	PNS0121	PNS2019			ic	ød	s	r	la
	VCGW160402-1NE0000005	CBST30S	●	●	●	●	VCGW33(0.5)-1NE0000005	CBST30S	9.525	4.4	4.76	0.4	3.0
	-1NS0101505		●	●	●	●	-1NS0101505						
	-1NS0102510		●	●	●	●	-1NS0102510						
	VCGW160404-1NE0000005		●	●	●	●	VCGW331-1NE0000005						
	-1NS0101505		●	●	●	●	-1NS0101505						
	-1NS0102510		●	●	●	●	-1NS0102510						
	VCGW160408-1NE0000005		●	●	●	●	VCGW332-1NE0000005						
	-1NS0101505		●	●	●	●	-1NS0101505						
	-1NS0102510		●	●	●	●	-1NS0102510						
	VCGW160402-2NE0000005	CBST30S	●	●	●	●	VCGW33(0.5)-2NE0000005	CBST30S	9.525	4.4	4.76	0.4	3.0
	-2NS0101505		●	●	●	●	-2NS0101505						
	-2NS0102510		●	●	●	●	-2NS0102510						
	VCGW160404-2NE0000005		●	●	●	●	VCGW331-2NE0000005						
	-2NS0101505		●	●	●	●	-2NS0101505						
	-2NS0102510		●	●	●	●	-2NS0102510						
	VCGW160408-2NE0000005		●	●	●	●	VCGW332-2NE0000005						
	-2NS0101505		●	●	●	●	-2NS0101505						
	-2NS0102510		●	●	●	●	-2NS0102510						

Examples: ISO: VCGW160404-2NS0101505 CBST30S PNS0115  
 ANSI: VCGW331-2NS0101505 CBST30S PNS0115

# Specifications of Standard PCBN Insert

**CN** 80° PCBN Negative Inserts

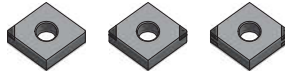

Sharp Cutting Edge	Standard Cutting Edge	Strong Cutting Edge
E000005	S0101505	S0102510

Shape	ISO	Tip Shape	S				ANSI	Tip Shape	Dimensions in mm					
			PNS0115	PNS0119	PNS0121	PNS2019			ic	ød	s	r	la	
	CNGA 120402-1NE000005	CBST30S	●	●	●	●	CNGA43(0.5)-1NE000005	CBST30S	12.7	5.16	4.76		0.2	3.0
	-1NS0101505		●	●	●	●	-1NS0101505							
	-1NS0102510		●	●	●	●	-1NS0102510							
	CNGA 120404-1NE000005						CNGA431-1NE000005							
	-1NS0101505		●	●	●	●	-1NS0101505							
	-1NS0102510		●	●	●	●	-1NS0102510							
	CNGA 120408-1NE000005						CNGA432-1NE000005							
	-1NS0101505		●	●	●	●	-1NS0101505							
	-1NS0102510		●	●	●	●	-1NS0102510							
	CNGA 120412-1NE000005						CNGA433-1NE000005							
	-1NS0101505		●	●	●	●	-1NS0101505							
	-1NS0102510		●	●	●	●	-1NS0102510							
	CNGA 120402-2NE000005	CBST30S	●	●	●	●	CNGA43(0.5)-2NE000005	CBST30S	12.7	5.16	4.76		0.2	3.0
	-2NS0101505		●	●	●	●	-2NS0101505							
	-2NS0102510		●	●	●	●	-2NS0102510							
	CNGA 120404-2NE000005						CNGA431-2NE000005							
	-2NS0101505		●	●	●	●	-2NS0101505							
	-2NS0102510		●	●	●	●	-2NS0102510							
	CNGA 120408-2NE000005						CNGA432-2NE000005							
	-2NS0101505		●	●	●	●	-2NS0101505							
	-2NS0102510		●	●	●	●	-2NS0102510							
	CNGA 120412-2NE000005						CNGA433-2NE000005							
	-2NS0101505		●	●	●	●	-2NS0101505							
	-2NS0102510		●	●	●	●	-2NS0102510							
	CNGA 120402-4NE000005	CBST30S	●	●	●	●	CNGA43(0.5)-4NE000005	CBST30S	12.7	5.16	4.76		0.2	3.0
	-4NS0101505		●	●	●	●	-4NS0101505							
	-4NS0102510		●	●	●	●	-4NS0102510							
	CNGA 120404-4NE000005						CNGA431-4NE000005							
	-4NS0101505		●	●	●	●	-4NS0101505							
	-4NS0102510		●	●	●	●	-4NS0102510							
	CNGA 120408-4NE000005						CNGA432-4NE000005							
	-4NS0101505		●	●	●	●	-4NS0101505							
	-4NS0102510		●	●	●	●	-4NS0102510							
	CNGA 120412-4NE000005						CNGA433-4NE000005							
	-4NS0101505		●	●	●	●	-4NS0101505							
	-4NS0102510		●	●	●	●	-4NS0102510							

Examples: ISO: CNGA 120404-4NS0101505 CBST30S PNS0115  
 ANSI: CNGA431-4NS0101505 CBST30S PNS0115

# Specifications of Standard PCBN Insert

**DN**

55° PCBN Negative Inserts

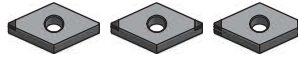

Sharp Cutting Edge	Standard Cutting Edge	Strong Cutting Edge
E000005	S0101505	S0102510

Shape	ISO	Tip Shape	S				ANSI	Tip Shape	Dimensions in mm				
			PNS0115	PNS0119	PNS0121	PNS2019			ic	ød	s	r	la
	DNGA 150402-1NE000005	CBST30S	●	●	●	●	DNGA43(0.5)-1NE000005	CBST30S	12.7	5.16	4.76	3.0	0.2
	-1NS0101505		●	●	●	●	-1NS0101505						0.4
	-1NS0102510		●	●	●	●	-1NS0102510						0.8
	DNGA 150404-1NE000005		●	●	●	●	DNGA431-1NE000005						1.2
	-1NS0101505		●	●	●	●	-1NS0101505						
	-1NS0102510		●	●	●	●	-1NS0102510						
	DNGA 150408-1NE000005		●	●	●	●	DNGA432-1NE000005						
	-1NS0101505		●	●	●	●	-1NS0101505						
	-1NS0102510		●	●	●	●	-1NS0102510						
	DNGA 150412-1NE000005		●	●	●	●	DNGA433-1NE000005						
	-1NS0101505		●	●	●	●	-1NS0101505						
	-1NS0102510		●	●	●	●	-1NS0102510						
	DNGA 150402-2NE000005	CBST30S	●	●	●	●	DNGA43(0.5)-2NE000005	CBST30S	12.7	5.16	4.76	3.0	0.2
	-2NS0101505		●	●	●	●	-2NS0101505						0.4
	-2NS0102510		●	●	●	●	-2NS0102510						0.8
	DNGA 150404-2NE000005		●	●	●	●	DNGA431-2NE000005						1.2
	-2NS0101505		●	●	●	●	-2NS0101505						
	-2NS0102510		●	●	●	●	-2NS0102510						
	DNGA 150408-2NE000005		●	●	●	●	DNGA432-2NE000005						
	-2NS0101505		●	●	●	●	-2NS0101505						
	-2NS0102510		●	●	●	●	-2NS0102510						
	DNGA 150412-2NE000005		●	●	●	●	DNGA433-2NE000005						
	-2NS0101505		●	●	●	●	-2NS0101505						
	-2NS0102510		●	●	●	●	-2NS0102510						
	DNGA 150402-4NE000005	CBST30S	●	●	●	●	DNGA43(0.5)-4NE000005	CBST30S	12.7	5.16	4.76	3.0	0.2
	-4NS0101505		●	●	●	●	-4NS0101505						0.4
	-4NS0102510		●	●	●	●	-4NS0102510						0.8
	DNGA 150404-4NE000005		●	●	●	●	DNGA431-4NE000005						1.2
	-4NS0101505		●	●	●	●	-4NS0101505						
	-4NS0102510		●	●	●	●	-4NS0102510						
	DNGA 150408-4NE000005		●	●	●	●	DNGA432-4NE000005						
	-4NS0101505		●	●	●	●	-4NS0101505						
	-4NS0102510		●	●	●	●	-4NS0102510						
	DNGA 150412-4NE000005		●	●	●	●	DNGA433-4NE000005						
	-4NS0101505		●	●	●	●	-4NS0101505						
	-4NS0102510		●	●	●	●	-4NS0102510						

Examples: ISO: DNGA 150404-4NS0101505 CBST30S PNS0115  
 ANSI: DNGA431-4NS0101505 CBST30S PNS0115

# Specifications of Standard PCBN Insert

**DN**

55° PCBN Negative Inserts

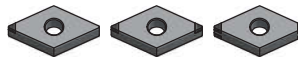

Sharp Cutting Edge	Standard Cutting Edge	Strong Cutting Edge
E000005	S0101505	S0102510

Shape	ISO	Tip Shape	S				ANSI	Tip Shape	Dimensions in mm				
			PNS0115	PNS0119	PNS0121	PNS0119			ic	ød	s	r	la
	DNGA 150602-1NE000005	CBST30S	●	●	●	●	DNGA44(0.5)-1NE000005	CBST30S	12.7	5.16	6.35	0.2	3.0
	-1NS0101505		●	●	●	●	-1NS0101505						
	-1NS0102510		●	●	●	●	-1NS0102510						
	DNGA 150604-1NE000005		●	●	●	●	DNGA441-1NE000005						
	-1NS0101505		●	●	●	●	-1NS0101505						
	-1NS0102510		●	●	●	●	-1NS0102510						
	DNGA 150608-1NE000005		●	●	●	●	DNGA442-1NE000005						
	-1NS0101505		●	●	●	●	-1NS0101505						
	-1NS0102510		●	●	●	●	-1NS0102510						
	DNGA 150612-1NE000005		●	●	●	●	DNGA443-1NE000005						
-1NS0101505	●	●	●	●	-1NS0101505								
-1NS0102510	●	●	●	●	-1NS0102510								
	DNGA 150602-2NE000005	CBST30S	●	●	●	●	DNGA44(0.5)-2NE000005	CBST30S	12.7	5.16	6.35	0.2	3.0
	-2NS0101505		●	●	●	●	-2NS0101505						
	-2NS0102510		●	●	●	●	-2NS0102510						
	DNGA 150604-2NE000005		●	●	●	●	DNGA441-2NE000005						
	-2NS0101505		●	●	●	●	-2NS0101505						
	-2NS0102510		●	●	●	●	-2NS0102510						
	DNGA 150608-2NE000005		●	●	●	●	DNGA442-2NE000005						
	-2NS0101505		●	●	●	●	-2NS0101505						
	-2NS0102510		●	●	●	●	-2NS0102510						
	DNGA 150612-2NE000005		●	●	●	●	DNGA443-2NE000005						
-2NS0101505	●	●	●	●	-2NS0101505								
-2NS0102510	●	●	●	●	-2NS0102510								
	DNGA 150602-4NE000005	CBST30S	●	●	●	●	DNGA44(0.5)-4NE000005	CBST30S	12.7	5.16	6.35	0.2	3.0
	-4NS0101505		●	●	●	●	-4NS0101505						
	-4NS0102510		●	●	●	●	-4NS0102510						
	DNGA 150604-4NE000005		●	●	●	●	DNGA441-4NE000005						
	-4NS0101505		●	●	●	●	-4NS0101505						
	-4NS0102510		●	●	●	●	-4NS0102510						
	DNGA 150608-4NE000005		●	●	●	●	DNGA442-4NE000005						
	-4NS0101505		●	●	●	●	-4NS0101505						
	-4NS0102510		●	●	●	●	-4NS0102510						
	DNGA 150612-4NE000005		●	●	●	●	DNGA443-4NE000005						
-4NS0101505	●	●	●	●	-4NS0101505								
-4NS0102510	●	●	●	●	-4NS0102510								

Examples: ISO: DNGA 150604-2NS0101505 CBST30S PNS0115  
 ANSI: DNGA441-2NS0101505 CBST30S PNS0115



# Specifications of Standard PCBN Insert

**SN** 90° PCBN Negative Inserts

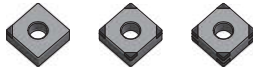

Sharp Cutting Edge	Standard Cutting Edge	Strong Cutting Edge
E000005	S0101505	S0102510

Shape	ISO	Tip Shape	S				ANSI	Tip Shape	Dimensions in mm				
			PNS0115	PNS0119	PNS0121	PNS2019			ic	ød	s	r	la
	SNGA 120402-1NE000005	CBST30S	●	●	●	●	SNGA43(0.5)-1NE000005	CBST30S	12.7	5.16	4.76	0.2	3.0
	-1NS0101505		●	●	●	●	-1NS0101505						
	-1NS0102510		●	●	●	●	-1NS0102510						
	SNGA 120404-1NE000005		●	●	●	●	SNGA431-1NE000005						
	-1NS0101505		●	●	●	●	-1NS0101505						
	-1NS0102510		●	●	●	●	-1NS0102510						
	SNGA 120408-1NE000005		●	●	●	●	SNGA432-1NE000005						
	-1NS0101505		●	●	●	●	-1NS0101505						
	-1NS0102510		●	●	●	●	-1NS0102510						
	SNGA 120412-1NE000005		●	●	●	●	SNGA433-1NE000005						
-1NS0101505	●	●	●	●	-1NS0101505								
-1NS0102510	●	●	●	●	-1NS0102510								
	SNGA 120402-2NE000005	CBST30S	●	●	●	●	SNGA43(0.5)-2NE000005	CBST30S	12.7	5.16	4.76	0.2	3.0
	-2NS0101505		●	●	●	●	-2NS0101505						
	-2NS0102510		●	●	●	●	-2NS0102510						
	SNGA 120404-2NE000005		●	●	●	●	SNGA431-2NE000005						
	-2NS0101505		●	●	●	●	-2NS0101505						
	-2NS0102510		●	●	●	●	-2NS0102510						
	SNGA 120408-2NE000005		●	●	●	●	SNGA432-2NE000005						
	-2NS0101505		●	●	●	●	-2NS0101505						
	-2NS0102510		●	●	●	●	-2NS0102510						
	SNGA 120412-2NE000005		●	●	●	●	SNGA433-2NE000005						
-2NS0101505	●	●	●	●	-2NS0101505								
-2NS0102510	●	●	●	●	-2NS0102510								
	SNGA 120402-4NE000005	CBST30S	●	●	●	●	SNGA43(0.5)-4NE000005	CBST30S	12.7	5.16	4.76	0.2	3.0
	-4NS0101505		●	●	●	●	-4NS0101505						
	-4NS0102510		●	●	●	●	-4NS0102510						
	SNGA 120404-4NE000005		●	●	●	●	SNGA431-4NE000005						
	-4NS0101505		●	●	●	●	-4NS0101505						
	-4NS0102510		●	●	●	●	-4NS0102510						
	SNGA 120408-4NE000005		●	●	●	●	SNGA432-4NE000005						
	-4NS0101505		●	●	●	●	-4NS0101505						
	-4NS0102510		●	●	●	●	-4NS0102510						
	SNGA 120412-4NE000005		●	●	●	●	SNGA433-4NE000005						
-4NS0101505	●	●	●	●	-4NS0101505								
-4NS0102510	●	●	●	●	-4NS0102510								

Examples: ISO: SNGGA120404-4NS0101505 CBST30S PNS0115  
 ANSI: SNGA431-4NS0101505 CBST30S PNS0115

# Specifications of Standard PCBN Insert

**SN**

90° PCBN Negative Inserts



Sharp Cutting Edge	Standard Cutting Edge	Strong Cutting Edge
E000005	S0101505	S0102510

Shape	ISO	Tip Shape	S				ANSI	Tip Shape	Dimensions in mm					
			PNS0115	PNS0119	PNS0121	PNS2019			ic	ød	s	r	la	
	SNGN090402-1NE000005	CBST30S	●	●	●	●	SNGA33(0.5)-1NE000005	CBST30S	9.252	-	4.76		3.0	0.2
	-1NS0101505		●	●	●	●	-1NS0101505							0.4
	-1NS0102510		●	●	●	●	-1NS0102510							0.8
	SNGN090404-1NE000005		●	●	●	●	SNGA331-1NE000005							1.2
	-1NS0101505		●	●	●	●	-1NS0101505							
	-1NS0102510		●	●	●	●	-1NS0102510							
	SNGN090408-1NE000005		●	●	●	●	SNGA332-1NE000005							
	-1NS0101505		●	●	●	●	-1NS0101505							
	-1NS0102510		●	●	●	●	-1NS0102510							
	SNGN090412-1NE000005		●	●	●	●	SNGA333-1NE000005							
-1NS0101505	●	●	●	●	-1NS0101505									
-1NS0102510	●	●	●	●	-1NS0102510									
	SNGN090402-4NE000005	CBST30S	●	●	●	●	SNGA33(0.5)-4NE000005	CBST30S	9.525	-	4.76		3.0	0.2
	-4NS0101505		●	●	●	●	-4NS0101505							0.4
	-4NS0102510		●	●	●	●	-4NS0102510							0.8
	SNGN090404-4NE000005		●	●	●	●	SNGA331-4NE000005							1.2
	-4NS0101505		●	●	●	●	-4NS0101505							
	-4NS0102510		●	●	●	●	-4NS0102510							
	SNGN090408-4NE000005		●	●	●	●	SNGA332-4NE000005							
	-4NS0101505		●	●	●	●	-4NS0101505							
	-4NS0102510		●	●	●	●	-4NS0102510							
	SNGN090412-4NE000005		●	●	●	●	SNGA333-4NE000005							
-4NS0101505	●	●	●	●	-4NS0101505									
-4NS0102510	●	●	●	●	-4NS0102510									
	SNGN090402-8NE000005	CBST30S	●	●	●	●	SNGA33(0.5)-8NE000005	CBST30S	9.525	-	4.76		3.0	0.2
	-8NS0101505		●	●	●	●	-8NS0101505							0.4
	-8NS0102510		●	●	●	●	-8NS0102510							0.8
	SNGN090404-8NE000005		●	●	●	●	SNGA331-8NE000005							1.2
	-8NS0101505		●	●	●	●	-8NS0101505							
	-8NS0102510		●	●	●	●	-8NS0102510							
	SNGN090408-8NE000005		●	●	●	●	SNGA332-8NE000005							
	-8NS0101505		●	●	●	●	-8NS0101505							
	-8NS0102510		●	●	●	●	-8NS0102510							
	SNGN090412-8NE000005		●	●	●	●	SNGA333-8NE000005							
-8NS0101505	●	●	●	●	-8NS0101505									
-8NS0102510	●	●	●	●	-8NS0102510									

Examples: ISO: SNGN090404-4NS0101505 CBST30S PNS0115  
 ANSI: SNGN331-4NS0101505 CBST30S PNS0115

# Specifications of Standard PCBN Insert

**TN** 60° PCBN Negative Inserts



Sharp Cutting Edge	Standard Cutting Edge	Strong Cutting Edge
E000005	S0101505	S0102510

Shape	ISO	Tip Shape	S				ANSI	Tip Shape	Dimensions in mm				
			PNS0115	PNS0119	PNS0121	PNS0119			ic	ød	s	r	la
	TNGA 160402-1NE0000005	CBST30S	●	●	●	●	TNGA33(0.5)-1NE0000005	CBST30S	9.525	3.81	4.76	3.0	0.2
	-1NS0101505		●	●	●	●	-1NS0101505						0.4
	-1NS0102510		●	●	●	●	-1NS0102510						0.8
	TNGA 160404-1NE0000005		●	●	●	●	TNGA331-1NE0000005						1.2
	-1NS0101505		●	●	●	●	-1NS0101505						
	-1NS0102510		●	●	●	●	-1NS0102510						
	TNGA 160408-1NE0000005		●	●	●	●	TNGA332-1NE0000005						
	-1NS0101505		●	●	●	●	-1NS0101505						
	-1NS0102510		●	●	●	●	-1NS0102510						
	TNGA 160412-1NE0000005		●	●	●	●	TNGA333-1NE0000005						
	-1NS0101505		●	●	●	●	-1NS0101505						
	-1NS0102510		●	●	●	●	-1NS0102510						
	TNGA 160402-3NE0000005	CBST30S	●	●	●	●	TNGA33(0.5)-3NE0000005	CBST30S	9.525	3.81	4.76	3.0	0.2
	-3NS0101505		●	●	●	●	-3NS0101505						0.4
	-3NS0102510		●	●	●	●	-3NS0102510						0.8
	TNGA 160404-3NE0000005		●	●	●	●	TNGA331-3NE0000005						1.2
	-3NS0101505		●	●	●	●	-3NS0101505						
	-3NS0102510		●	●	●	●	-3NS0102510						
	TNGA 160408-3NE0000005		●	●	●	●	TNGA332-3NE0000005						
	-3NS0101505		●	●	●	●	-3NS0101505						
	-3NS0102510		●	●	●	●	-3NS0102510						
	TNGA 160412-3NE0000005		●	●	●	●	TNGA333-3NE0000005						
	-3NS0101505		●	●	●	●	-3NS0101505						
	-3NS0102510		●	●	●	●	-3NS0102510						
	TNGA 160402-6NE0000005	CBST30S	●	●	●	●	TNGA33(0.5)-6NE0000005	CBST30S	9.525	3.81	4.76	3.0	0.2
	-6NS0101505		●	●	●	●	-6NS0101505						0.4
	-6NS0102510		●	●	●	●	-6NS0102510						0.8
	TNGA 160404-6NE0000005		●	●	●	●	TNGA331-6NE0000005						1.2
	-6NS0101505		●	●	●	●	-6NS0101505						
	-6NS0102510		●	●	●	●	-6NS0102510						
	TNGA 160408-6NE0000005		●	●	●	●	TNGA332-6NE0000005						
	-6NS0101505		●	●	●	●	-6NS0101505						
	-6NS0102510		●	●	●	●	-6NS0102510						
	TNGA 160412-6NE0000005		●	●	●	●	TNGA333-6NE0000005						
	-6NS0101505		●	●	●	●	-6NS0101505						
	-6NS0102510		●	●	●	●	-6NS0102510						

Examples: ISO: TNGA 160404-6NS0101505 CBST30S PNS0115  
 ANSI: TNGA331-6NS0101505 CBST30S PNS0115

# Specifications of Standard PCBN Insert

**VN** 35° PCBN Negative Inserts

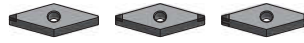

Sharp Cutting Edge	Standard Cutting Edge	Strong Cutting Edge
E000005	S0101505	S0102510

Shape	ISO	Tip Shape	S				ANSI	Tip Shape	Dimensions in mm				
			PNS0115	PNS0119	PNS0121	PNS2019			ic	ød	s	r	la
	VNGA 160402-1NE000005	CBST30S	●	●	●	●	VNGA33(0.5)-1NE000005	CBST30S	9.525	3.81	4.76	0.2	3.0
	-1NS0101505		●	●	●	●	-1NS0101505						
	-1NS0102510		●	●	●	●	-1NS0102510						
	VNGA 160404-1NE000005		●	●	●	●	VNGA331-1NE000005						
	-1NS0101505		●	●	●	●	-1NS0101505						
	-1NS0102510		●	●	●	●	-1NS0102510						
	VNGA 160408-1NE000005		●	●	●	●	VNGA332-1NE000005						
	-1NS0101505		●	●	●	●	-1NS0101505						
	-1NS0102510		●	●	●	●	-1NS0102510						
	VNGA 160412-1NE000005		●	●	●	●	VNGA333-1NE000005						
-1NS0101505	●	●	●	●	-1NS0101505								
-1NS0102510	●	●	●	●	-1NS0102510								
	VNGA 160402-2NE000005	CBST30S	●	●	●	●	VNGA33(0.5)-2NE000005	CBST30S	9.525	3.81	4.76	0.2	3.0
	-2NS0101505		●	●	●	●	-2NS0101505						
	-2NS0102510		●	●	●	●	-2NS0102510						
	VNGA 160404-2NE000005		●	●	●	●	VNGA331-2NE000005						
	-2NS0101505		●	●	●	●	-2NS0101505						
	-2NS0102510		●	●	●	●	-2NS0102510						
	VNGA 160408-2NE000005		●	●	●	●	VNGA332-2NE000005						
	-2NS0101505		●	●	●	●	-2NS0101505						
	-2NS0102510		●	●	●	●	-2NS0102510						
	VNGA 160412-2NE000005		●	●	●	●	VNGA333-2NE000005						
-2NS0101505	●	●	●	●	-2NS0101505								
-2NS0102510	●	●	●	●	-2NS0102510								
	VNGA 160402-4NE000005	CBST30S	●	●	●	●	VNGA33(0.5)-4NE000005	CBST30S	9.525	3.81	4.76	0.2	3.0
	-4NS0101505		●	●	●	●	-4NS0101505						
	-4NS0102510		●	●	●	●	-4NS0102510						
	VNGA 160404-4NE000005		●	●	●	●	VNGA331-4NE000005						
	-4NS0101505		●	●	●	●	-4NS0101505						
	-4NS0102510		●	●	●	●	-4NS0102510						
	VNGA 160408-4NE000005		●	●	●	●	VNGA332-4NE000005						
	-4NS0101505		●	●	●	●	-4NS0101505						
	-4NS0102510		●	●	●	●	-4NS0102510						
	VNGA 160412-4NE000005		●	●	●	●	VNGA333-4NE000005						
-4NS0101505	●	●	●	●	-4NS0101505								
-4NS0102510	●	●	●	●	-4NS0102510								

Examples: ISO: VNGA 160404-2NS0101505 CBST30S PNS0115  
 ANSI: VNGA331-2NS0101505 CBST30S PNS0115

# Specifications of Standard PCBN Insert



80° PCBN Negative Inserts



Sharp Cutting Edge	Standard Cutting Edge	Strong Cutting Edge
E000005	S0101505	S0102510

Shape	ISO	Tip Shape	S				ANSI	Tip Shape	Dimensions in mm				
			PNS0115	PNS0119	PNS0121	PNS2019			ic	ød	s	r	la
	WNGA080402-1NE0000005	CBST30S	●	●	●	●	WNGA43(0.5)-1NE0000005	CBST30S	12.7	5.16	4.76	3.0	0.2
	-1NS0101505		●	●	●	●	-1NS0101505						0.4
	-1NS0102510		●	●	●	●	-1NS0102510						0.8
	WNGA080404-1NE0000005		●	●	●	●	WNGA431-1NE0000005						1.2
	-1NS0101505		●	●	●	●	-1NS0101505						
	-1NS0102510		●	●	●	●	-1NS0102510						
	WNGA080408-1NE0000005		●	●	●	●	WNGA432-1NE0000005						
	-1NS0101505		●	●	●	●	-1NS0101505						
	-1NS0102510		●	●	●	●	-1NS0102510						
	WNGA080412-1NE0000005		●	●	●	●	WNGA433-1NE0000005						
	-1NS0101505		●	●	●	●	-1NS0101505						
	-1NS0102510		●	●	●	●	-1NS0102510						
	WNGA080402-3NE0000005	CBST30S	●	●	●	●	WNGA43(0.5)-3NE0000005	CBST30S	12.7	5.16	4.76	3.0	0.2
	-3NS0101505		●	●	●	●	-3NS0101505						0.4
	-3NS0102510		●	●	●	●	-3NS0102510						0.8
	WNGA080404-3NE0000005		●	●	●	●	WNGA431-3NE0000005						1.2
	-3NS0101505		●	●	●	●	-3NS0101505						
	-3NS0102510		●	●	●	●	-3NS0102510						
	WNGA080408-3NE0000005		●	●	●	●	WNGA432-3NE0000005						
	-3NS0101505		●	●	●	●	-3NS0101505						
	-3NS0102510		●	●	●	●	-3NS0102510						
	WNGA080412-3NE0000005		●	●	●	●	WNGA433-3NE0000005						
	-3NS0101505		●	●	●	●	-3NS0101505						
	-3NS0102510		●	●	●	●	-3NS0102510						
	WNGA080402-6NE0000005	CBST30S	●	●	●	●	WNGA43(0.5)-6NE0000005	CBST30S	12.7	5.16	4.76	3.0	0.2
	-6NS0101505		●	●	●	●	-6NS0101505						0.4
	-6NS0102510		●	●	●	●	-6NS0102510						0.8
	WNGA080404-6NE0000005		●	●	●	●	WNGA431-6NE0000005						1.2
	-6NS0101505		●	●	●	●	-6NS0101505						
	-6NS0102510		●	●	●	●	-6NS0102510						
	WNGA080408-6NE0000005		●	●	●	●	WNGA432-6NE0000005						
	-6NS0101505		●	●	●	●	-6NS0101505						
	-6NS0102510		●	●	●	●	-6NS0102510						
	WNGA080412-6NE0000005		●	●	●	●	WNGA433-6NE0000005						
	-6NS0101505		●	●	●	●	-6NS0101505						
	-6NS0102510		●	●	●	●	-6NS0102510						

Examples: ISO: WNGA080404-6NS0101505 CBST30S PNS0115  
 ANSI: WNGA431-6NS0101505 CBST30S PNS0115

# Specifications of Wiper PCBN Insert

## CC 80° PCBN Negative Inserts

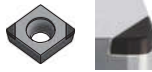

Sharp Cutting Edge	Standard Cutting Edge	Strong Cutting Edge
E0000005	S0101505	S0102510

Shape	ISO	Tip Shape	S				ANSI	Tip Shape	Dimensions in mm				
			PNS0115	PNS0119	PNS0121	PNS2019			ic	ød	s	r	la
	CCGW09T304-2NE0000005	CBWG22S	●	●	●	●	CCGW3(2.5)1-2NE0000005	CBWG22S	9.525	4.4	3.97	0.8	2.2
	-2NS0101505		●	●	●	●	-2NS0101505						
	-2NS0102510		●	●	●	●	-2NS0102510						
	CCGW09T308-2NE0000005		●	●	●	●	CCGW3(2.5)2-2NE0000005						
	-2NS0101505		●	●	●	●	-2NS0101505						
	-2NS0102510		●	●	●	●	-2NS0102510						

## DC 55° PCBN Negative Inserts

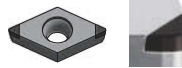

Sharp Cutting Edge	Standard Cutting Edge	Strong Cutting Edge
E0000005	S0101505	S0102510

Shape	ISO	Tip Shape	S				ANSI	Tip Shape	Dimensions in mm				
			PNS0115	PNS0119	PNS0121	PNS2019			ic	ød	s	r	la
	DCGW070204-2NE0000005	CBWG22S	●	●	●	●	DCGW2(1.5)1-2NE0000005	CBWG22S	6.35	2.8	2.38	0.8	2.2
	-2NS0101505		●	●	●	●	-2NS0101505						
	-2NS0102510		●	●	●	●	-2NS0102510						
	DCGW070208-2NE0000005		●	●	●	●	DCGW2(1.5)2-2NE0000005						
	-2NS0101505		●	●	●	●	-2NS0101505						
	-2NS0102510		●	●	●	●	-2NS0102510						

## DC 55° PCBN Negative Inserts

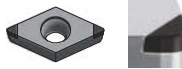

Sharp Cutting Edge	Standard Cutting Edge	Strong Cutting Edge
E0000005	S0101505	S0102510

Shape	ISO	Tip Shape	S				ANSI	Tip Shape	Dimensions in mm				
			PNS0115	PNS0119	PNS0121	PNS2019			ic	ød	s	r	la
	DCGW11T304-2NE0000005	CBWG22S	●	●	●	●	DCGW3(2.5)1-2NE0000005	CBWG22S	9.525	4.4	3.97	0.8	2.2
	-2NS0101505		●	●	●	●	-2NS0101505						
	-2NS0102510		●	●	●	●	-2NS0102510						
	DCGW11T308-2NE0000005		●	●	●	●	DCGW3(2.5)2-2NE0000005						
	-2NS0101505		●	●	●	●	-2NS0101505						
	-2NS0102510		●	●	●	●	-2NS0102510						

Examples: ISO: DCGW11T304-2NS0101505 CBWG22S PNS0115  
 ANSI: DCGW3(2.5)1-2NS0101505 CBWG22S PNS0115

# Specifications of Wiper PCBN Insert

## SC 90° PCBN Negative Inserts



Sharp Cutting Edge	Standard Cutting Edge	Strong Cutting Edge
E0000005	S0101505	S0102510

Shape	ISO	Tip Shape	S				ANSI	Tip Shape	Dimensions in mm				
			PNS0115	PNS0119	PNS0121	PNS2019			ic	∅d	s	r	la
	SCGN090404-4NE0000005	CBWG22S	●	●	●	●	SCGN331-4NE0000005	CBWG22S	9.525	4.76	3.97	0.8	2.2
	-4NS0101505		●	●	●	●	-4NS0101505						
	-4NS0102510		●	●	●	●	-4NS0102510						
	SCGN090408-4NE0000005		●	●	●	●	SCGN33(0.5)2-4NE0000005						
	-4NS0101505		●	●	●	●	-4NS0101505						
	-4NS0102510		●	●	●	●	-4NS0102510						

## CN 80° PCBN Negative Inserts



Sharp Cutting Edge	Standard Cutting Edge	Strong Cutting Edge
E0000005	S0101505	S0102510

Shape	ISO	Tip Shape	S				ANSI	Tip Shape	Dimensions in mm				
			PNS0115	PNS0119	PNS0121	PNS2019			ic	∅d	s	r	la
	CNGA120404-2NE0000005	CBWG22S	●	●	●	●	CNGA431-2NE0000005	CBWG22S	12.7	5.16	4.76	0.8	2.2
	-2NS0101505		●	●	●	●	-2NS0101505						
	-2NS0102510		●	●	●	●	-2NS0102510						
	CNGA120408-2NE0000005		●	●	●	●	CNGA432-2NE0000005						
	-2NS0101505		●	●	●	●	-2NS0101505						
	-2NS0102510		●	●	●	●	-2NS0102510						

## DN 55° PCBN Negative Inserts

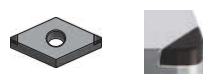

Sharp Cutting Edge	Standard Cutting Edge	Strong Cutting Edge
E0000005	S0101505	S0102510

Shape	ISO	Tip Shape	S				ANSI	Tip Shape	Dimensions in mm				
			PNS0115	PNS0119	PNS0121	PNS2019			ic	∅d	s	r	la
	DNGA150404-2NE0000005	CBWG22S	●	●	●	●	DNGA431-2NS0101005	CBWG22S	12.7	5.16	4.76	0.8	2.2
	-2NS0101505		●	●	●	●	-2NS0101510						
	-2NS0102510		●	●	●	●	-2NS0152020						
	DNGA150408-2NE0000005		●	●	●	●	DNGA432-2NS0101005						
	-2NS0101505		●	●	●	●	-2NS0101510						
	-2NS0102510		●	●	●	●	-2NS0152020						

Examples: ISO: DNGA150404-2NS0101505 CBWG22S PNS0115  
 ANSI: DNGA431-2NS0101505 CBWG22S PNS0115

# Specifications of Wiper PCBN Insert

## DN 55° PCBN Negative Inserts

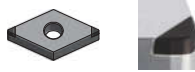

Sharp Cutting Edge	Standard Cutting Edge	Strong Cutting Edge
E0000005	S0101505	S0102510

Shape	ISO	Tip Shape	S				ANSI	Tip Shape	Dimensions in mm				
			PNS0115	PNS0119	PNS0121	PNS2019			ic	∅d	s	r	la
	DNGA150604-2NE0000005	CBWG22S	●	●	●	●	DNGA441-2NE0000005	CBWG22S	12.7	5.16	6.35	0.4	2.2
	-2NS0101505		●	●	●	●	-2NS0101505						
	-2NS0102510		●	●	●	●	-2NS0102510						
	DNGA150608-2NE0000005		●	●	●	●	DNGA442-2NE0000005						
	-2NS0101505		●	●	●	●	-2NS0101505						
	-2NS0102510		●	●	●	●	-2NS0102510						

## TN 60° PCBN Negative Inserts



Sharp Cutting Edge	Standard Cutting Edge	Strong Cutting Edge
E0000005	S0101505	S0102510

Shape	ISO	Tip Shape	S				ANSI	Tip Shape	Dimensions in mm				
			PNS0115	PNS0119	PNS0121	PNS2019			ic	∅d	s	r	la
	TNGA160404-3NE0000005	CBWG22S	●	●	●	●	TNGA331-3NE0000005	CBWG22S	9.525	3.81	4.76	0.4	2.2
	-3NS0101505		●	●	●	●	-2NS0101505						
	-3NS0102510		●	●	●	●	-2NS0102510						
	TNGA160408-3NE0000005		●	●	●	●	TNGA332-3NE0000005						
	-3NS0101505		●	●	●	●	-2NS0101505						
	-3NS0102510		●	●	●	●	-2NS0102510						

## WN 80° PCBN Negative Inserts



Sharp Cutting Edge	Standard Cutting Edge	Strong Cutting Edge
E0000005	S0101505	S0102510

Shape	ISO	Tip Shape	S				ANSI	Tip Shape	Dimensions in mm				
			PNS0115	PNS0119	PNS0121	PNS2019			ic	∅d	s	r	la
	WNGA080404-3NE0000005	CBWG22S	●	●	●	●	WNGA431-3NE0000005	CBWG22S	12.7	5.16	4.76	0.8	2.2
	-3NS0101505		●	●	●	●	-3NS0101505						
	-3NS0102510		●	●	●	●	-3NS0102510						
	WNGA080408-3NE0000005		●	●	●	●	WNGA432-3NE0000005						
	-3NS0101505		●	●	●	●	-3NS0101505						
	-3NS0102510		●	●	●	●	-3NS0102510						

Examples: ISO: WNGA080404-3NS0101505 CBWG22S PNS0115

ANSI: WNGA431-3NS0101505 CBWG22S PNS0115



# Cutting Direction Recommendation

## External machining

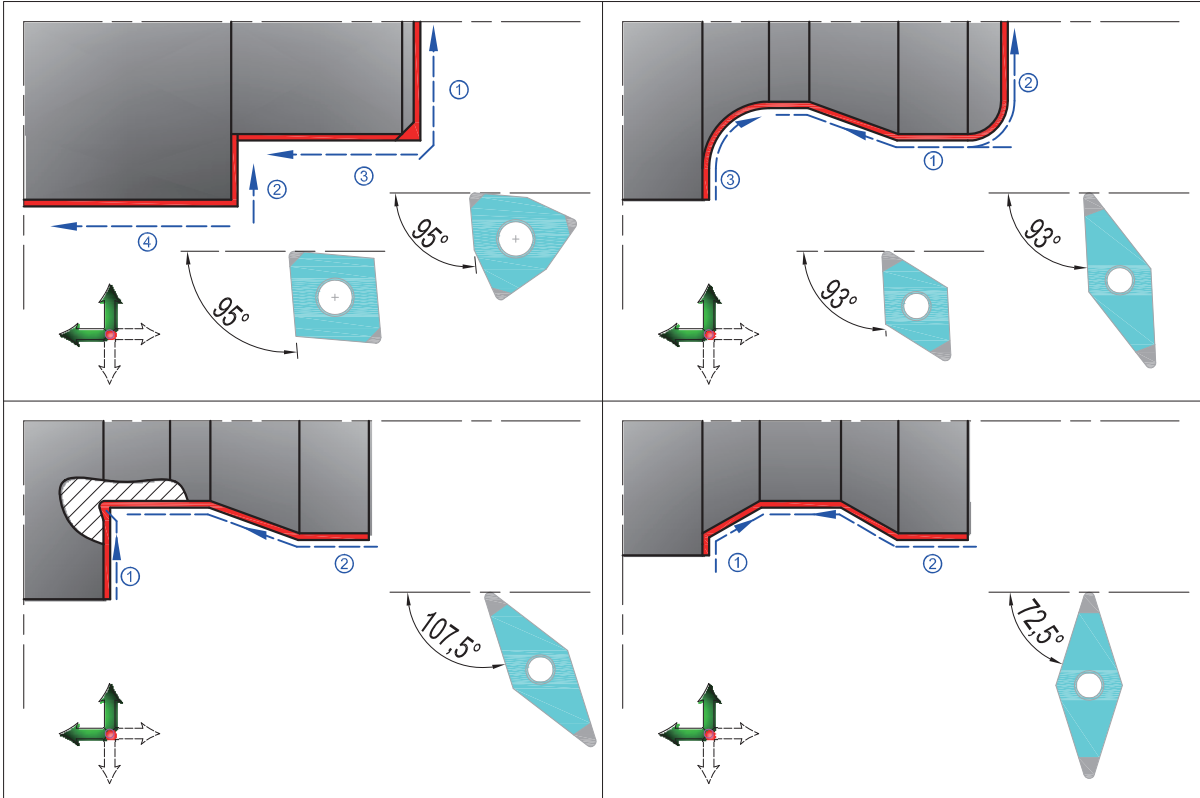

## Internal machining

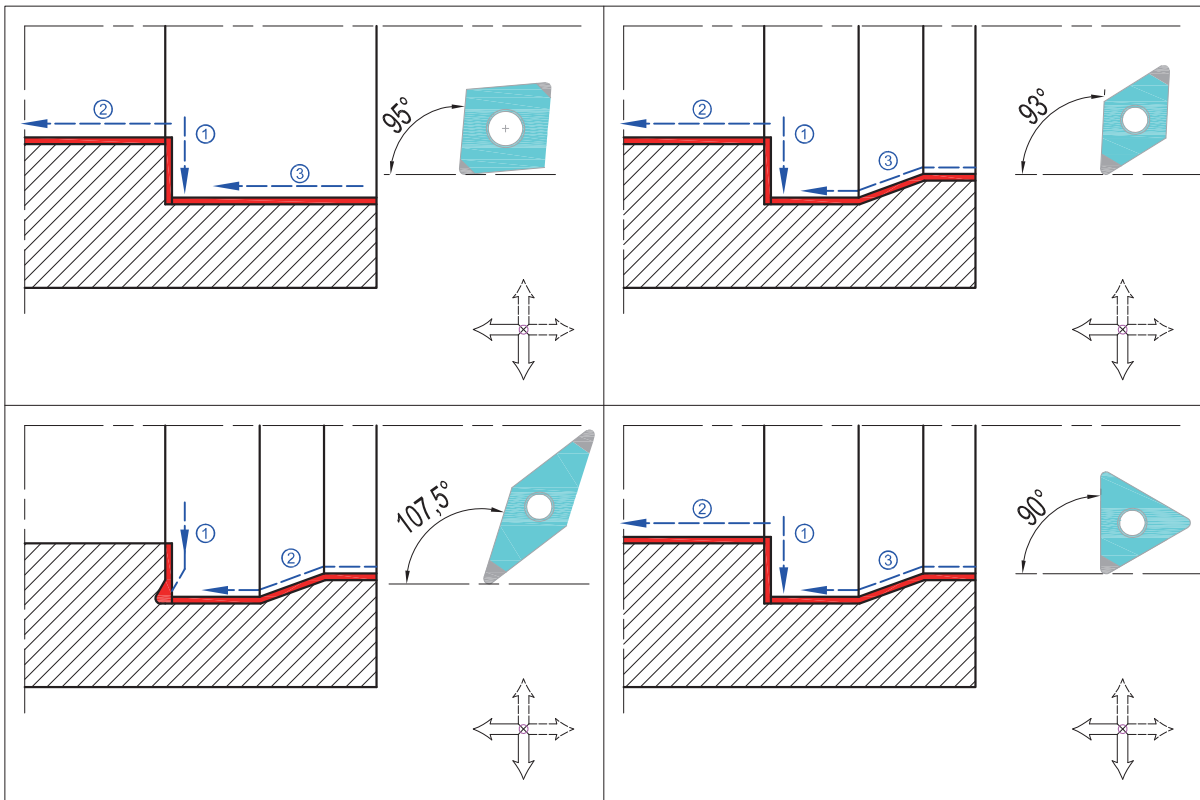

# Nose radius, Feed Rate Against Surface Finish Spindle Speed Recommendation

## ■ Influence of nose radius and feed rate on the surface finish.

The table below gives recommended maximum feed rates to achieve a special Ra. Value.

$$h = r\epsilon - (r\epsilon^2 - (0.5 \times f)^2) 0.5$$

$$f_{\max} = (Ra \times r\epsilon / 50) \frac{1}{2}$$

Nose radius (mm)	Surface finish Ra value(μm)					
	0.2	0.4	0.8	1.6	3.2	6.4
	feed (mm/rev) rate ≅					
0.2	0.028	0.040	0.057	0.080	0.113	0.160
0.4	0.040	0.057	0.080	0.113	0.160	0.226
0.8	0.057	0.080	0.113	0.160	0.226	0.320
1.2	0.069	0.098	0.139	0.196	0.277	0.392
1.6	0.080	0.113	0.160	0.226	0.320	0.453
2.4	0.098	0.139	0.196	0.277	0.392	0.554

## ■ Spindle speed recommendation

Speed (m/min)	Workpiece/Tool Holer Diameter (mm)													
	12	16	20	25	32	50	63	80	100	125	160	175	200	250
80	2123	1592	1274	1019	796	510	404	318	255	204	159	146	127	102
90	2389	1791	1433	1146	896	573	455	358	287	229	179	164	143	115
100	2654	1990	1592	1274	995	637	506	398	318	255	199	182	159	127
110	2919	2189	1752	1401	1095	701	556	438	350	280	219	200	175	140
120	3185	2389	1911	1529	1194	764	607	478	382	306	239	218	191	153
140	3715	2787	2229	1783	1393	892	708	557	446	357	279	255	223	178
160	4246	3185	2548	2038	1592	1019	809	637	510	408	318	291	255	204
180	4777	3583	2866	2293	1791	1146	910	717	573	459	358	328	287	229
200	5308	3981	3185	2548	1990	1274	1011	796	637	510	398	364	318	255
220	5839	4379	3503	2803	2189	1401	1112	876	701	561	438	400	350	280
240	6369	4777	3822	3057	2389	1529	1213	955	764	611	478	437	382	306
260	6900	5175	4140	3312	2588	1656	1314	1035	828	662	518	473	414	331
280	7431	5573	4459	3567	2787	1783	1415	1115	892	713	557	510	446	357
300		5971	4777	3822	2986	1911	1517	1194	955	764	597	546	478	382
400						2548	2022	1592	1274	1019	796	728	637	510
600						3822	3033	2389	1911	1529	1194	1092	955	764
800						5096	4044	3185	2548	2038	1592	1456	1274	1019
1000						6369	5055	3981	3185	2548	1990	1820	1592	1274

# Hardness Conversion Charts

## ■ Hardness Conversion Charts

According to Germany standard DIN50150, the following is the reference list for the steel's usual range of vickers hardness, brinell hardness and rockwell hardness.

Tensile Strength Rm N/mm	Vickers Hardness HV	Brinell Hardness HB	Rockwell Hardness HRC	Tensile Strength Rm N/mm	Vickers Hardness HV	Brinell Hardness HB	Rockwell Hardness HRC
250	80	76.0	-	595	185	176	-
270	85	80.7	-	610	190	181	-
285	90	85.2	-	625	195	185	-
305	95	90.2	-	640	200	190	-
320	100	95.0	-	660	205	195	-
335	105	99.8	-	675	210	199	-
350	110	105	-	690	215	204	-
370	115	109	-	705	220	209	-
380	120	114	-	720	225	214	-
400	125	119	-	740	230	219	-
415	130	124	-	755	235	223	-
430	135	128	-	770	240	228	20.3
450	140	133	-	785	245	233	21.3
465	145	138	-	800	250	238	22.2
480	150	143	-	820	255	242	23.1
490	155	147	-		840		65.3
510	160	152	-		860		65.9
530	165	156	-		880		66.4
545	170	162	-		900		67.0
560	175	166	-		920		67.5
575	180	171	-		940		68.0



**WORLDIA**

**COMPETE FOR THE TOP    CREATE GLOBAL BRAND**



[www.worldiatools.com](http://www.worldiatools.com)  
[www.cuttingtoolchina.com](http://www.cuttingtoolchina.com)

**Tel :** +86-10-58411388    **Fax :** +86-10-58411388-8030

**Add :** No.2 Industry Road ,Dachang Chaobaihe Industrial Park,  
Langfang City,Hebei Province 065300,China

**E-mail :** [marketing@worldiatools.com](mailto:marketing@worldiatools.com)

